

PulsaPro[®] XAE

NEMA 4X, 7
STROKE LENGTH ACTUATOR

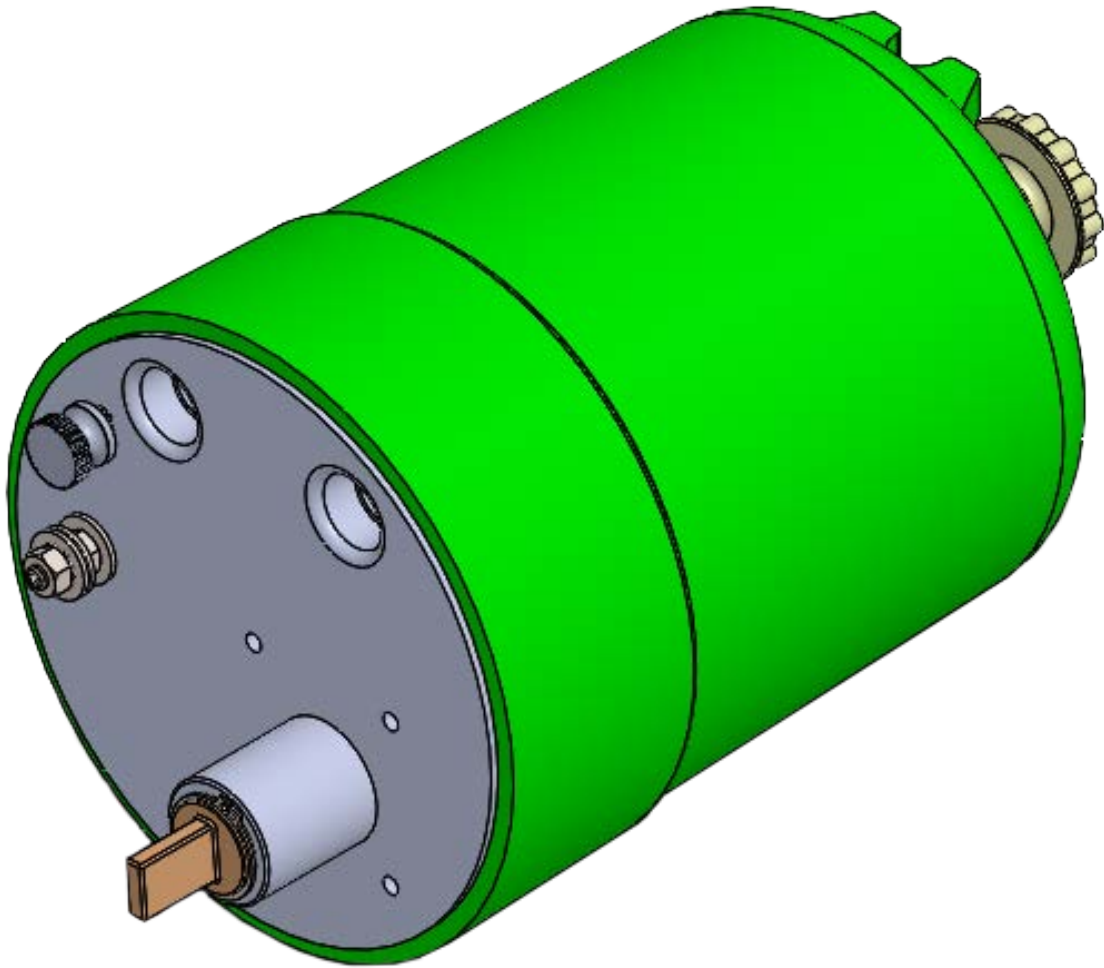

Installation, Operation & Maintenance Manual

Bulletin: IOM-CTL-XAE-2007 REV B

AE FACTORY SERVICE POLICY

Your XAE is a state of the art microprocessor-based stroke length control device for use with PULSAPRO Diaphragm Metering Pumps. Upon receipt of your new PULSAPRO diaphragm metering pump, activate the warranty by registering the serial number at svcportal.pulsa.com. If you are experiencing a problem with your XAE, go to the Pulsafeeder Service Portal to consult the troubleshooting guide in your operation and maintenance manual, refer to the frequently asked question lists, and search the Service Forum for direction and answers to solve the problem. If the issue is not covered or cannot be solved, by clicking on the Contact Us section in the Pulsafeeder Service Portal, details to connect with your local Pulsafeeder Sales Representative and our Technical Services are provided.

Trained individuals are available to diagnose your problem and arrange a solution. Solutions may include purchasing a replacement unit or returning the XAE to the factory for inspection and repair.

All returns require a Return Material Authorization (R.M.A.) number to be issued by Pulsafeeder. Parts purchased to correct a warranty issue may be credited after examination of the original parts by Pulsafeeder personnel. Parts returned for warranty considerations which are good will be sent back freight collect.

Any field modifications will void the warranty. Out-of-warranty repairs will be subject to Pulsafeeder's standard bench fees and testing costs associated with replacement components.

Some product features are controlled by UL for ordinary and hazardous locations. Those features and this document cannot be changed without notification or approval of Pulsafeeder.

FCC WARNING

This equipment generates and uses radio frequency energy. If not installed and used properly, in strict accordance with the manufacturer's instructions, it may cause interference to radio communications. Operation of this equipment in a residential area is likely to cause interference in which case the user, at his own expense, will be required to take whatever measures necessary to correct the interference.

REVISION HISTORY

Rev. #	Author(s)	Revision Date	Approved By	Approval Date	Reason
A	AH/EVB	05/02/2017	EVB	06/22/2017	1ST-RELEASE
B	EVB	05/11/2018	EVB	05/25/2018	ADDED PULSA

COPYRIGHT

Copyright © 2017 Pulsafeeder, Inc. All rights reserved.

Information in this document is subject to change without notice. No part of this publication may be reproduced, stored in a retrieval system or transmitted in any form or any means electronic or mechanical, including photocopying and recording for any purpose other than the purchaser's personal use without the written permission of Pulsafeeder.

Table of Contents

1. INTRODUCTION	6
2. FOREWORD	6
2.1 DESCRIPTION	6
2.2 XAE STANDARD FEATURES	6
3. SAFETY CONSIDERATIONS	6
3.1 GENERAL SAFETY.....	7
3.2 ELECTRICAL SAFETY.....	7
3.3 EXPLOSIVE ATMOSPHERE SAFETY	7
3.4 FIRE SAFETY.....	7
3.5 HYDRAULIC SAFETY	8
3.6 LIABILITY EXCLUSION.....	8
4. SUITABILITY TO SITE OF INSTALLATION	8
4.1 NAMEPLATE AND MARKING	8
5. EQUIPMENT INSPECTION	9
6. TRANSPORT AND STORAGE	10
6.1 CONSIGNMENT RECEIPT AND UNPACKING	10
6.2 HANDLING	10
6.3 LIFTING	10
6.4 RECYCLING AND END OF PRODUCT LIFE	10
7. STORAGE INSTRUCTIONS	10
7.1 SHORT TERM (0 - 12 MONTHS).....	10
7.2 LONG TERM (12 MONTHS OR MORE)	10
8. INSTALLATION AND WIRING	11
8.1 COMPONENT OVERVIEW	11
8.2 LOCATION	11
8.3 INSTALLATION NOTES.....	11
8.4 CODES AND REGULATIONS	12
8.5 INSTALLATION GUIDELINES FOR EMC COMPLIANCE – PENDING TESTING	12
8.6 HOUSING ACCESS	12
8.7 ELECTRICAL WIRING	13
8.8 POWER WIRING INFORMATION	13
8.9 GROUNDING INFORMATION	15
8.10 CONTROL INPUT AND OUTPUT CONNECTIONS	16
8.10.1 Analog Input (Current Loop)	17
8.10.2 Analog Output (Current Loop)	17
8.11 Dry Contact Inputs	19
8.11.1 RUN	19
8.11.2 ALARM Input	20
8.11.3 PERMISSIVE INTERLOCK (RESET) INPUT.....	21
8.12 OUTPUTS.....	22

8.12.1	RUNNING OUTPUT	22
8.12.2	Alarm Output.....	23
8.12.3	AUTO/MANUAL Output	24
9.	START-UP AND OPERATION	26
9.1	OVERVIEW	26
9.2	USER INTERFACE	26
9.3	SETUP & CALIBRATION	27
9.3.1	Analog Input Signal Calibration	27
9.3.2	Analog Output Signal Calibration	28
9.3.3	MECHANICAL CALIBRATION (0%/100%)	28
10.	ADVANCED PROCEDURE – ADDITION/REPLACEMENT OF XAE	29
11.	FACTORY RE-INITIALIZATION	38
12.	DIAGNOSTICS	39
12.1	TROUBLE CODE REPORTING.....	39
12.1.1	Trouble Code Table	40
12.2	POWER-ON-SELF TEST	41
12.3	DIAGNOSTIC LED's.....	41
12.4	ERROR RECOVERY.....	42
13.	SPECIFICATIONS.....	42
14.	WIRING DIAGRAM.....	44
15.	FIELD WIRING SUMMARY.....	45
16.	TROUBLESHOOTING GUIDE	45
17.	MAINTENANCE & SPARE PARTS.....	46
17.1	OPERATING PRECAUTIONS	46
17.2	CLEANING AND DECONTAMINATION	46
17.3	USER REPLACEABLE PARTS FOR THE XAE	46
18.	APPENDIX.....	47

CONVENTIONS

For the remainder of this document, the following conventions are in effect.



A WARNING DEFINES A CONDITION THAT COULD CAUSE DAMAGE TO BOTH THE EQUIPMENT AND THE PERSONNEL OPERATING IT. THIS MANUAL MUST BE CONSULTED IN ALL CASES WHERE THE WARNING SYMBOL IS MARKED IN ORDER TO FIND OUT THE NATURE OF THE POTENTIAL HAZARDS AND ANY ACTIONS, WHICH HAVE TO BE TAKEN TO AVOID THEM.



CAUTION, POSSIBILITY OF ELECTRIC SHOCK



NOTES ARE GENERAL INFORMATION MEANT TO MAKE OPERATING THE EQUIPMENT EASIER.



TIPS HAVE BEEN INCLUDED WITHIN THIS BULLETIN TO HELP THE OPERATOR RUN THE EQUIPMENT IN THE MOST EFFICIENT MANNER POSSIBLE. THESE “TIPS” ARE DRAWN FROM THE KNOWLEDGE AND EXPERIENCE OF OUR STAFF ENGINEERS, AND INPUT FROM THE FIELD.

1. INTRODUCTION

The XAE is a microprocessor based stroke length control device for use with the PULSAPRO diaphragm-metering pump. It has been designed to operate in a variety of industrial environments. This document describes the XAE controller only. The operation and maintenance of the PULSAPRO metering pump is covered in the pump IOM. Please refer to this IOM for important safety and operational instructions for your XAE stroke length controller.

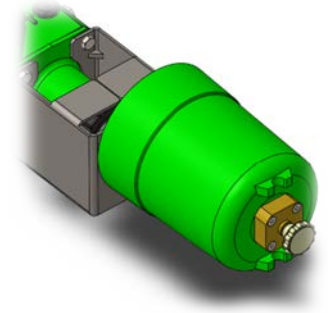

2. FOREWORD

The pump and controls to which these “instructions” refer to are designed for use in industrial areas and therefore cannot be treated as retail products. The present documentation gives instructions to be used by qualified personnel only. It must be used in compliance with the regulations, laws and technical standards in force and cannot, under any circumstances, take the place of plant standard or additional regulations, including any which are not legally enforceable, which have been issued with the scope of ensuring safety.

Equipment with special manufacturing or constructive variances may differ in details with respect to this description.

In case of any difficulty, please contact PULSAFEEDER, INC. Technical Service.

The PULSAPRO ® XAE is rated for NEMA 4x and 7 hazardous locations as identified on the controller nameplate.

Hazardous location – A hazardous location is defined as an explosive atmosphere due to the presence of flammable gasses, liquids, vapors, combustible dust, or ignitable fibers.

2.1 DESCRIPTION

The XAE is an electromechanical servo controller dedicated to the PULSAPRO diaphragm metering pump series. The unit is physically attached and integrated into the pump's design. The controller allows for precise adjustment of output flow of a process media by means of stroke length positioning.

The XAE is designed for the international industrial market. The analog control signals offer flexible remote control. They are isolated from earth ground for improved protection and reliability.

The XAE is designed to simplify and automate the calibration of the analog signals. Analog signal calibration is accomplished by simple push button entry. Calibration functions must be completed while the internal circuitry of the unit is accessible, and therefore at a time when the surrounding environment is considered safe for electronic work.

2.2 XAE STANDARD FEATURES

1. Electronic Stroke Length Control
2. NEMA 4x
3. 4-20mA input and output
4. AUTO/MANUAL Pull Switch - Manual over-ride of output setting
5. (3) Switch closure inputs for Interlock, Alarm and Run
6. (3) Relay outputs for Auto/Manual, Alarm and Run status

The XAE uses a switching power supply that can accept power from 100 to 240 VAC, at 50 to 60 Hz.

3. SAFETY CONSIDERATIONS

The XAE is a sophisticated microprocessor based controller for use only with PULSAPRO diaphragm metering pumps. It yields tremendous control capacity -- electrical, mechanical and (in conjunction with the PULSAPRO pump) hydraulic in nature. In consideration of SAFETY, the user should be mindful of this relative to his/her safety, that of co-workers and of the process environment. Please consider the following prior to the installation and operation of a XAE controlled PULSAPRO metering pump:

1. Read and understand all related instructions and documentation before attempting to install or maintain this equipment
2. Observe all special instructions, notes, and cautions.

3. Act with care and exercise good common sense and judgment during all installation, adjustment, and maintenance procedures.
4. Ensure that all safety rules, work procedures, and standards that are applicable to your company and facility are followed during the installation, maintenance, and operation of this equipment.

3.1 GENERAL SAFETY

The XAE was designed as a stroke length position actuator for operation solely with the PULSAPRO metering pump. Use for any other application is considered un-safe and voids all certification markings and warranties.

3.2 ELECTRICAL SAFETY

The XAE can be considered an industrial process controller. Improper application and use can be hazardous. You are solely responsible for its use.



THE XAE' S ELECTRICAL INSTALLATION MUST CONFORM TO ALL LOCAL, STATE AND NATIONAL RELEVANT ELECTRICAL CODES. INSTALLATION AND ELECTRICAL MAINTENANCE MUST BE PERFORMED BY A QUALIFIED ELECTRICIAN. BEFORE INSTALLING OR SERVICING THIS DEVICE, ALL POWER MUST BE DISCONNECTED FROM THE SOURCE AT THE MAIN DISTRIBUTION PANEL.

The XAE emits electro-magnetic energy and may generate radio frequency interference. Its use is restricted to industrial applications. You are responsible for shielding this energy/interference.



CERTAIN WIRING PROCEDURES MAY REQUIRE THAT THE USER WEAR A WRIST STRAP TO DISSIPATE STATIC CHARGES.

WARNING

INSTALLATION AND ELECTRICAL MAINTENANCE MUST BE PERFORMED BY A QUALIFIED ELECTRICIAN.



BEFORE INSTALLING OR SERVICING THIS DEVICE, ALL POWER MUST BE DISCONNECTED FROM THE SOURCE AT THE MAIN DISTRIBUTION PANEL. CERTAIN CALIBRATION FUNCTIONS MUST BE COMPLETED WHILE THE ELECTRONIC SECTION OF THE UNIT IS EXPOSED AND POWER IS APPLIED TO THE UNIT, BE CERTAIN TO ENSURE THAT PROPER PROCEDURES ARE FOLLOWED AND THAT FINGERS, TOOLS, AND WIRING DO NOT CONTACT EXPOSED CIRCUITRY AND COMPONENTS.

The XAE emits electromagnetic energy and generates radio frequency interference. Its use is restricted to industrial applications. The user bears all responsibility for shielding this energy/interference.

Certain wiring procedures may require that the user wear a wrist strap to dissipate static charges.

3.3 EXPLOSIVE ATMOSPHERE SAFETY



WARNING

EXPLOSION HAZARD -- DO NOT PERFORM INSTALLATION, CALIBRATION, OR MAINTENANCE OF ANY KIND ON THIS DEVICE WHILE CIRCUIT IS LIVE AND THE AREA IS KNOWN TO BE HAZARDOUS.

REMOVAL OF THE ENCLOSURE COVER TO PERFORM SIGNAL CALIBRATIONS MUST BE DONE ONLY IF THE AREA IS KNOWN TO BE NON-HAZARDOUS. CARE MUST BE TAKEN TO ENSURE PROPER RE-INSTALLATION OF THE COVER. REVIEW THIS ENTIRE MANUAL THOROUGHLY BEFORE PROCEEDING.

Under expected operating conditions, and with the proper marking, this equipment is suitable for use in:

- A. Class I, Division 1, Groups C & D
- B. Non-hazardous locations

3.4 FIRE SAFETY



WARNING

IN CASE OF ELECTRICAL FIRE, USE A CLASS C FIRE EXTINGUISHER. NEVER USE WATER TO EXTINGUISH A CLASS C FIRE.

Class C fires involve electrical equipment, such as appliances, wiring, circuit breakers and outlets. Never use water to extinguish class C fires - the risk of electrical shock is far too great! Class C extinguishers do not have a numerical rating. The C classification means the extinguishing agent is non-conductive. Geometric symbol (blue circle)

3.5 HYDRAULIC SAFETY

Thoroughly review and adhere to the contents of the PULSAPRO Installation, Operation, Maintenance Instruction manual (current version) for hydraulic installation of your PULSAPRO metering pump.

3.6 LIABILITY EXCLUSION

Pulsafeeder, Inc. is unable to monitor the observance of the instructions given in this manual, nor verify the actual working conditions and installation of the equipment, the correct operation and maintenance of the equipment and accessories. An incorrect installation, or misuse of the equipment, may cause serious damage and may pose a danger to persons or property. Any anomalies must be reported to the maintenance supervisor. The user is not authorized to tamper with the machine for any reason.



ATTEMPTS TO DISASSEMBLE, MODIFY OR TAMPER IN GENERAL BY UNAUTHORIZED PERSONNEL WILL VOID THE GUARANTEE AND WILL RELEASE PULSAFEEDER, INC. FROM ANY LIABILITY FOR DAMAGE CAUSED TO PERSONS OR PROPERTY RESULTING FROM SUCH ACTIONS.

Pulsafeeder, Inc. is considered released from any liability in the following cases:

1. Improper installation;
2. Improper use of the equipment by non-professional or inadequately trained operators;
3. Use not in compliance with regulations in the Country of use;
4. Lack of maintenance or improperly performed;
5. Use of non-original spare parts or incorrect parts for the model in question;
6. Total or partial failure to observe the instructions;
7. Exceptional environmental events.



DO NOT PERFORM ANY WORK ON THE PUMP, MOTOR OR XAE CONTROL UNIT WITH ELECTRICAL POWER CONNECTED TO THE XAE CONTROL UNIT. DO NOT OPERATE THE XAE UNIT WITH THE COVER REMOVED. DANGER OF ELECTRONIC SHOCK AND MECHANICAL PINCH HAZARD!



INSTALLATION AND REPAIRS SHOULD ONLY BE PERFORMED BY AUTHORIZED PERSONNEL! FOLLOW ALL SAFETY/ LOCAL LOCK-OUT, TAG-OUT PROCEDURES!

4. SUITABILITY TO SITE OF INSTALLATION

Essential safety requirements against explosion hazard in dangerous areas are regulated.



IT IS THE CUSTOMER'S RESPONSIBILITY BEFORE INSTALLATION AND FOLLOWING START-UP TO VERIFY AND ENSURE THAT THE PUMP/CONTROL IS ACTUALLY SUITABLE FOR THE AREA CLASSIFICATION AND FOR THE CHARACTERISTICS OF INFLAMMABLE SUBSTANCES PRESENT IN THE PLANT. Upon equipment receipt, verify that pumps/controls have not received any damage due to transportation and are complete with every eventual accessory. In case anomalies or damages are discovered prior to installation, please contact PULSAFEEDER, INC. Technical Service.





The following standards apply to the enclosure for this product:

Class I Division 1 and Class II Division 1	UL 1203 Edition 5	CSA C22.2 No. 30-1986 Reaffirmed 2012
		CSA C22.2 No. 25-1966 reaffirmed 2014

4.1 NAMEPLATE AND MARKING

The XAE bears a standard rating nameplate on which it is possible to read, apart from functional data, all data required for universal identification.

HAZARDOUS LOCATIONS

XAE STROKE LENGTH ACTUATOR	CAUTION:  TO PREVENT IGNITION OF HAZARDOUS ATMOSPHERES, COVER MUST BE TIGHT WHILE CIRCUITS ARE ENERGIZED. DISCONNECT FROM POWER SUPPLY BEFORE OPENING ENCLOSURE.
MODEL:	WARNING: TO REDUCE THE RISK OF IGNITION OF HAZARDOUS ATMOSPHERES, ALL CONDUIT RUNS MUST HAVE A SEALING FITTING CONNECTED WITHIN 18 INCHES (45 CM) OF THIS ENCLOSURE. MODEL XAE ENCLOSURE SUITABLE FOR USE IN CLASS I DIV 1 GROUPS C AND D LOCATIONS CONFORMS TO UL1203 CERTIFIED TO CSA C22.2 No. 30
SERIAL NUMBER:	
VOLTS/HZ/AMPS/PHASE:	
OPTIONS:	
 ENGINEERED PRODUCTS 2883 Brighton Henrietta Town Line Rd. Rochester, New York 14623	ETL CLASSIFIED  Intertek 3041035
	NEMA 7 NEMA 4X  

NON-HAZARDOUS LOCATIONS

XAE STROKE LENGTH ACTUATOR
MODEL: XAEX4XXXXX-XXXX
MFG. DATE: 05/25/17
VOLTS/HZ/AMPS/PHASE: 100-240VAC/50-60/2.6-1.0A/1P
OPTIONS: NEMA 4X
 2883 BRIGHTON-HENRIETTA RD ROCHESTER, NY 14472 USA

5. EQUIPMENT INSPECTION

Upon equipment receipt, verify that pump and controls have not received any damage due to transportation and are complete with every eventual accessory. In case anomalies or damages are discovered prior to installation, please contact PULSAFEEDER, INC. Technical Service.

6. TRANSPORT AND STORAGE

6.1 CONSIGNMENT RECEIPT AND UNPACKING

Immediately after receipt of the equipment it must be checked against the delivery/shipping documents for its completeness and that there has been no damage in transportation.

Check any crate, boxes or wrappings for any accessories or spare parts that may be packed separately with the equipment or attached to side walls of the box or equipment.

Each product has a unique serial number. Check that this number corresponds with that advised and always quotes this number in correspondence as well as when ordering spare parts or further accessories.

Shortages or damage should be reported immediately to the carrier and your Pulsafeeder Representative.

6.2 HANDLING

Boxes, crates, pallets or cartons may be unloaded using fork lift vehicles or slings dependent on their size and construction.

6.3 LIFTING

A crane must be used for all controller/pump sets in excess of 25 kg (55 lb.). Fully trained personnel must carry out lifting, in accordance with local regulations.

Slings, ropes and other lifting gear should be positioned where they cannot slip and where a balanced lift is obtained.

6.4 RECYCLING AND END OF PRODUCT LIFE

At the end of the service life of the product or its parts, the relevant materials and parts should be recycled or disposed of using an environmentally acceptable method and local requirements. If the product contains substances that are harmful to the environment, these should be removed and disposed of in accordance with current regulations. This also includes the liquids and/or gases that may be used in the "seal system" or other utilities.

Make sure that hazardous substances are disposed of safely and that the correct personal protective equipment is used. The safety specifications must be in accordance with the current regulations at all times.

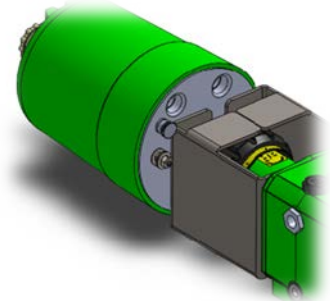

7. STORAGE INSTRUCTIONS

The XAE can be successfully stored for extended periods. The key to this success is control of temperature and humidity.

7.1 SHORT TERM (0 - 12 MONTHS)

The XAE should be stored in a temperature and humidity controlled environment. It is preferable to keep the temperature constant in the range of -18 to 40° Celsius (0 to 104° Fahrenheit). The relative humidity should be 0 to 90% non-condensing.

If the XAE is installed on the pump, it should not be removed during this period - provided the above conditions can be applied to the pump as well.



IF THE XAE IS REMOVED FROM THE PUMP GEAR BOX, IT SHOULD BE STORED IN THE SAME PUMP MOUNTED ORIENTATION. IF THE XAE WAS SHIPPED IN ITS OWN CARTON, IT SHOULD BE STORED IN THAT CARTON.

7.2 LONG TERM (12 MONTHS OR MORE)

Storage of the XAE for periods of longer than twelve months is not recommended. If extended storage is unavoidable, the XAE should be stored in accordance with those conditions stipulated for Short Term Storage. In addition, a porous bag of 85g (3 oz.) silica gel or similar desiccant should be placed within the enclosure. The cover should be re-installed to seal the desiccant within the enclosure. The two conduit connections must be tightly capped. Inspect the unit carefully for any signs of damage and remove the desiccant before placing it into operation.

8. INSTALLATION AND WIRING

8.1 COMPONENT OVERVIEW

From the exterior, the XAE includes the following features:

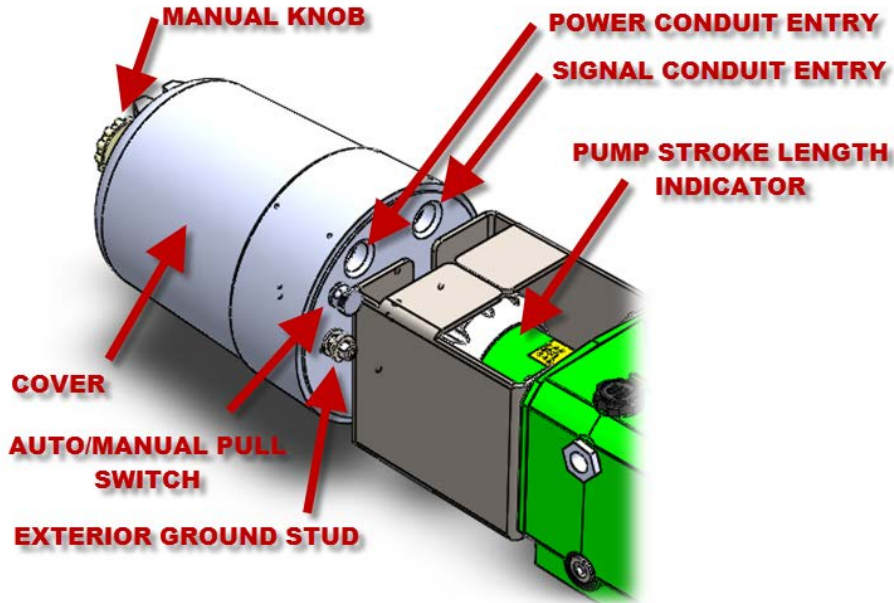

8.2 LOCATION

Review the Safety section prior to installing the XAE. It contains important information required to properly install and operate the XAE in industrial environments.

The site selected for the installation of your XAE is largely dependent on that of the PULSAPRO metering pump. Please review the PULSAPRO Installation Operation Maintenance Instruction Manual (current version) provided with your PULSAPRO metering pump. It details system related issues that are important to proper operation of the PULSAPRO metering pump. Be mindful of the following XAE related issues when selecting a site. Avoid locations where the XAE would be subjected to extreme cold or heat. Note the warning statement. The installation of this device must comply with national, state and local codes.



WARNING

AVOID LOCATIONS WHERE THE XAE WOULD BE SUBJECTED TO EXTREME COLD OR HEAT [LESS THAN -40°C (-40°F) OR GREATER THAN 50°C (122°F)] AND/OR DIRECT SUNLIGHT. FAILURE TO OBSERVE THIS WARNING COULD DAMAGE THE XAE AND VOID ITS WARRANTY.

8.3 INSTALLATION NOTES

1. The XAE is a microprocessor-based controller that uses static sensitive CMOS components. Do not make any electrical connections (high or low voltage) without adequately grounding the XAE and the worker to eliminate any electrostatic charge between the two. A conductive wrist strap worn by the worker and attached to the XAE enclosure is adequate to satisfy this requirement.
2. **Conduit connections can carry fluids and vapors into the XAE causing damage and void the warranty.** Care should be taken when installing conduit to protect against fluid/vapor entry. In accordance with any applicable codes provide sealed entries and conduit drains near the point of entry as required.
3. All applicable codes and regulations should be adhered to in the installation and wiring of the XAE.

Integrity of the enclosure

In normal operation there should be no unused entries. The power wiring should always be separated away from the signal wiring. If questions arise about the conduit or cable glands during installation or servicing contact Pulsafeeder field service or applications engineering for assistance.



WHEN USED IN HAZARDOUS ENVIRONMENTS, ALL ENCLOSURE ENTRIES MUST HAVE A SEAL WITHIN 18 INCHES (45CM) OF THE ENCLOSURE.

8.4 CODES AND REGULATIONS

All applicable codes and regulations should be adhered to in the installation and wiring of the XAE, especially if installed in a hazardous environment.



THE SAFETY OF ANY SYSTEM INCORPORATING THE XAE IS THE RESPONSIBILITY OF THE ASSEMBLER OF THE SYSTEM.

8.5 INSTALLATION GUIDELINES FOR EMC COMPLIANCE – PENDING TESTING

1. The cover must be installed properly.
2. Shielded cables used for analog inputs and outputs
3. Proper Earth grounding
4. Insure Power mains are properly filtered for isolation from line transients, lightning strikes, or other electrical noise sources.



FAILURE TO OBSERVE THE GUIDELINES ABOVE MAY LEAD TO ERRATIC AND POSSIBLY UNSAFE OPERATING CONDITIONS.

8.6 HOUSING ACCESS

All wiring and programming of the XAE must be accomplished through the removal of the housing cover. Use this procedure for removal and replacement:



EXPLOSION HAZARD: DO NOT PERFORM INSTALLATION, CALIBRATION, OR MAINTENANCE OF ANY KIND ON THIS DEVICE WHILE CIRCUIT IS LIVE AND THE AREA IS KNOWN TO BE HAZARDOUS.

REMOVAL OF THE ENCLOSURE COVER TO PERFORM SIGNAL CALIBRATIONS MUST BE DONE ONLY IF THE AREA IS KNOWN TO BE NON-HAZARDOUS. CARE MUST BE TAKEN TO ENSURE PROPER RE-INSTALLATION OF THE COVER. REVIEW THIS ENTIRE MANUAL THOROUGHLY BEFORE PROCESSING.

Cover Removal

1. Disconnect power at the source (follow your local Lock-Out-Tag-Out procedures).
2. Grasp the cover from the outside – one hand on each side - and rotate counter clockwise looking from the external knob end towards the pump.

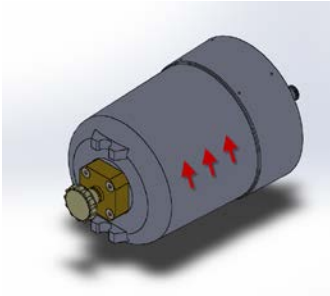

3. When cover threads are clear pull the cover straight back off over the internal components.

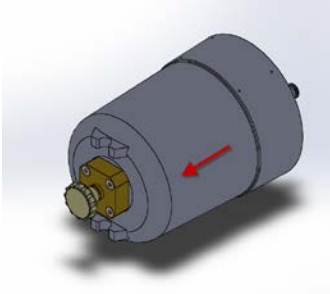

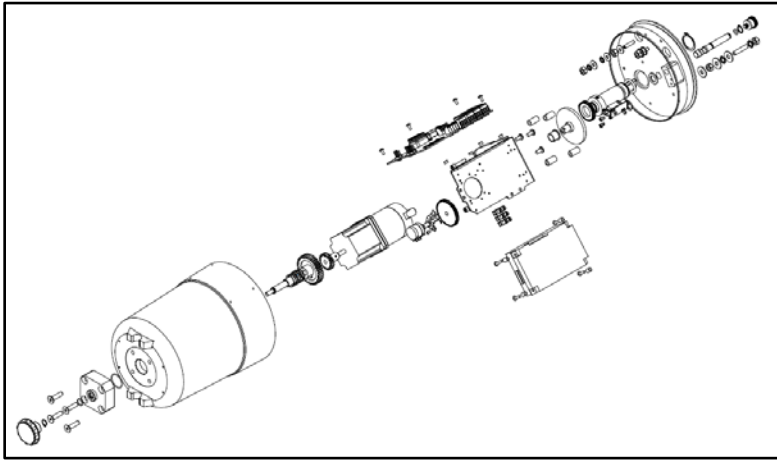

Cover Re-installation

1. Disconnect power at the source (follow your local Lock-out-Tag-out procedures).
2. Verify that the threads of the cover and based plate of the XAE are clean and well-greased.
3. Inspect wiring to assure it is neat and secured away from the cover surface.
4. Slide the open end of the enclosure over the electronic assembly. Assure no wires are caught or pinched.
5. Rotate the cover clockwise to tighten it onto the base plate.
6. Continue to rotate the cover until the edge contacts the flange on the base plate.

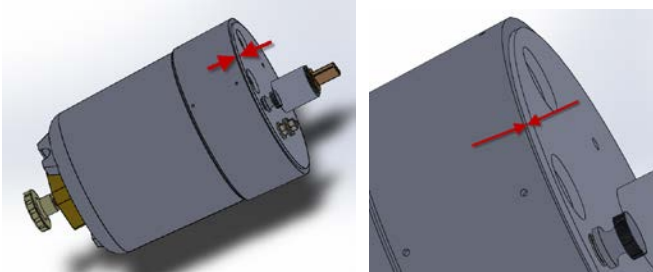

7. Check the cover contacts the flange with no air gaps.
8. When wiring is completed and cover is properly replaced, the XAE is now ready for operation. Remove Lock-out-Tag-out protection and restore power. See the Electrical Wiring section for further details.

8.7 ELECTRICAL WIRING



WARNING

WHILE THE XAE WIRING REQUIREMENTS ARE VERY SIMPLE, ALWAYS KEEP IN MIND THAT ACCESS TO THESE CONNECTORS REQUIRES THE REMOVAL OF THE COVER, AND AS SUCH THIS PROCEDURE SHOULD ONLY BE PERFORMED BY A TRAINED PROFESSIONAL.



WAIT A MINIMUM OF 3 MINUTES AFTER DISCONNECTING POWER BEFORE SERVICING THE XAE OR PUMP MOTOR. CAPACITORS RETAIN A CHARGE EVEN AFTER POWER IS REMOVED FROM THE CONTROLLER.

It is highly recommended that you take a step-by-step approach to wiring and confirming proper XAE operation:

1. Make the Line voltage connections. These will allow you to operate the XAE and attached Pulsafeeder pump.
2. Decide which low voltage Inputs and Outputs (e.g., 4-20mA in) will be used and make those connections.
3. Power-up and test the XA to confirm the connections and check for proper operation.

8.8 POWER WIRING INFORMATION



WARNING

THESE PROCEDURES REQUIRE REMOVAL OF THE ENCLOSURE COVER. THIS SHOULD BE DONE ONLY IF THE AREA IS KNOWN TO BE SAFE FOR ELECTRONIC WORK.



VERIFY THE CORRECT SUPPLY VOLTAGE (100VAC TO 240VAC) WITH THE NAMEPLATE AFFIXED TO YOUR XAE. ENSURE THAT YOUR SUPPLY VOLTAGE MATCHES THE XAE CONFIGURATION.



WARNING

WIRES SHOULD BE ROUTED WITHIN THE ENCLOSURE IN A MANNER THAT MAINTAINS SEPARATION BETWEEN LINE VOLTAGE AND EXTRA-LOW VOLTAGE CONDUCTORS.

APPLICABLE NATIONAL AND LOCAL ELECTRICAL CODES TAKE PRECEDENCE OVER RECOMMENDATIONS IN THE TABLE BELOW.

Model	Recommended Minimum Wiring and Circuit Breaker											
	100 VAC Operation						240 VAC Operation					
	Avg. Draw	Max Nom. Draw	Inrush Current	Circuit Breaker	Wire Size	Wire Size	Avg. Draw	Max Nom. Draw	Inrush Current	Circuit Breaker	Wire Size	Wire Size
XAE	500 mA	2.6 A	20A	10 A	14 AWG	2.5 mm ²	250 mA	1.0 A	40A	10 A	14 AWG	2.5 mm ²

A CIRCUIT BREAKER OR FUSE MUST BE PROVIDED AS NOTED BELOW.

Power In

Wire: 10-20AWG (Solid or Stranded)

Insulation Strip Length: 0.3 in (8 mm)

Terminal Screw Torque: 7 in-lbs. (0.8 N-m)

Note the XAE input current ratings from the name plate and check the applicable electrical codes for required wire type and size, grounding requirements, over-current protection, and incoming power disconnect (Lock out/Tag out) before wiring the controller.

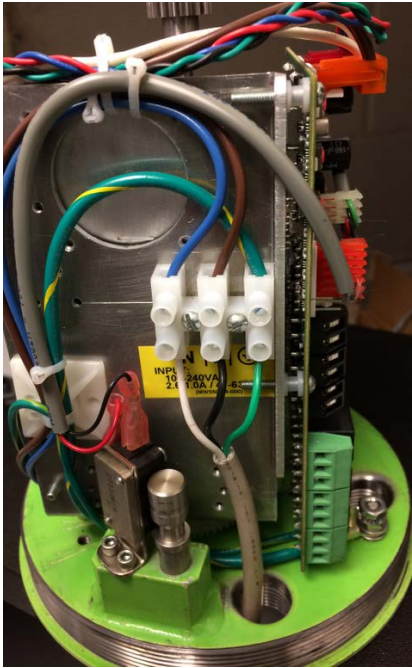

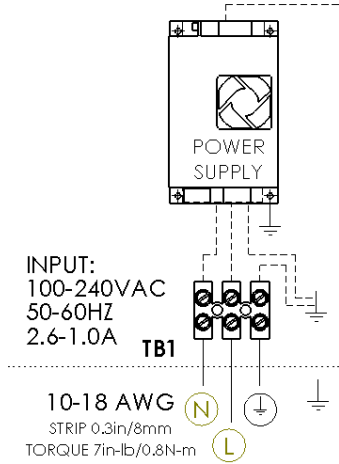

INPUT:
100-240VAC
50-60HZ
2.6-1.0A

10-18 AWG
STRIP 0.3in/8mm
TORQUE 7in-lb/0.8N-m



N | L | ⏚
INPUT:
100-240VAC
2.6-1.0A / 47-63Hz
(MW550004-000)

Wiring of TB1 Connector with Labeling Detail

Connect the proper AC voltage supply to power the XAE on the terminal block labeled TB1.

- The Neutral wire is connected to the terminal labeled “N” (the corresponding wire color is blue).
- The Line wire is connected to the terminal labeled “L” (the corresponding wire color is brown).
- The Earth wire is connected to the terminal labeled with the “Ground” symbol (the corresponding wire color is green with yellow stripe).

The connector is rated for 10-20AWG (Solid or Stranded) copper wire. Remove approximately 0.3 inches, (7-8mm) of insulation from the end of each conductor. Loosen the terminal strip screw, and insert the stripped wire end fully into the terminal. Tighten the screw to 7 in-lb (0.8 N-m) to secure the conductor. Make certain that the terminal grips the wire, not the insulation. If the power supplied to the unit does not match the factory configuration (shown on the nameplate), it will malfunction/damage and void the warranty.



POWER WIRING SHOULD HAVE A RATING OF AT LEAST 300 VOLTS AC (RMS) AND A TEMPERATURE RATING OF AT LEAST 105 DEGREES C.



A CIRCUIT BREAKER OR DISCONNECT SWITCH WITH FUSES, MUST BE PROVIDED IN ACCORDANCE WITH ALL APPLICABLE LOCAL AND NATIONAL ELECTRICAL CODES AND REGULATIONS. SIZE EXTERNAL FUSING/BREAKER FOR RATINGS FOR THE WIRING USED FOR THE UNIT.

APPLICABLE NATIONAL AND LOCAL ELECTRICAL CODES TAKE PRECEDENCE OVER RECOMMENDATIONS MADE HERE.

TO ENSURE PROPER OPERATION, THE XAE SHOULD REMAIN POWERED AT ALL TIMES.

INPUT POWER MUST BE RUN IN SEPARATE CONDUIT. DO NOT COMBINE POWER AND CONTROL WIRES IN A COMMON CONDUIT!

FIELD WIRING CONDUCTORS SHALL BE COPPER CONDUCTORS ONLY!

8.9 GROUNDING INFORMATION



APPLICABLE NATIONAL AND LOCAL ELECTRICAL CODES TAKE PRECEDENCE OVER RECOMMENDATIONS

The primary incoming power electrical ground should be attached to TB1 as defined in section Power Wiring. In addition, one (Non-Hazardous location) or two (Hazardous location) other ground locations are provided for use where grounding requirements exceed single point terminal blocks. One is located inside the enclosure – between the conduit openings. The second is located outside the enclosure below the Auto/Manual switch. These locations are depicted below:

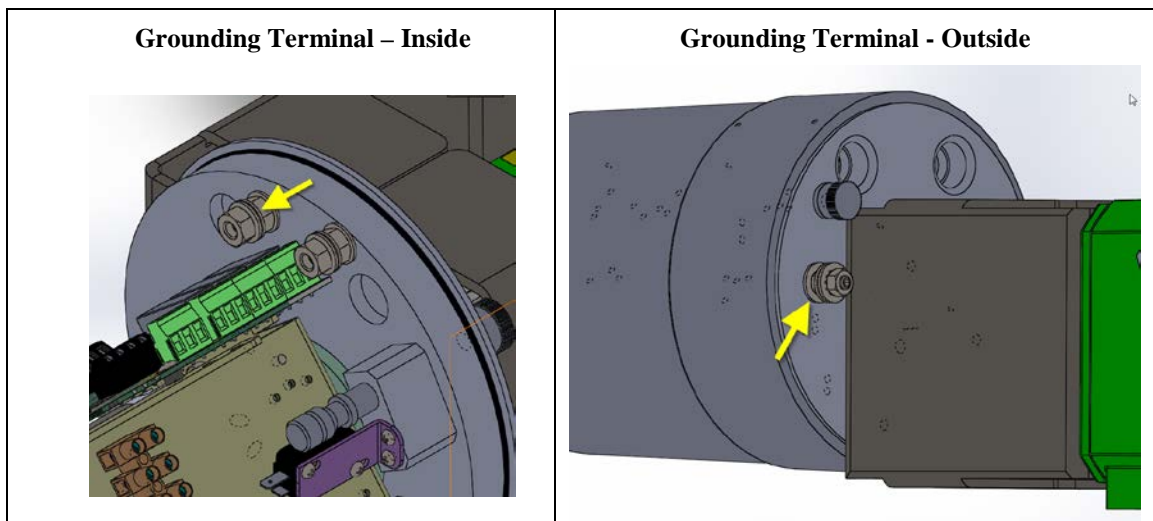

8.10 CONTROL INPUT AND OUTPUT CONNECTIONS

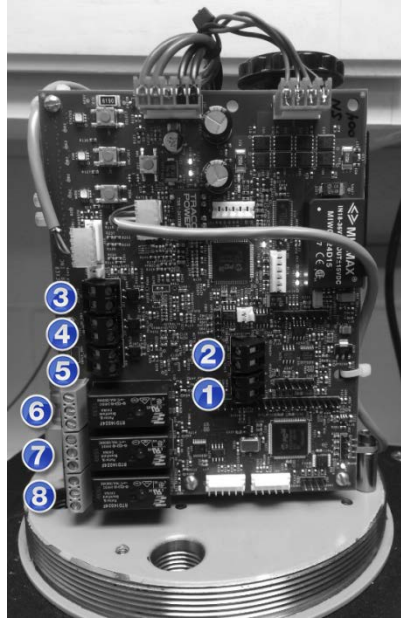

Input/Output User Connections:

- 1 - 4-20 mA Input
- 2 - 4-20 mA Output
- 3 - Call-To-Run Input (Dry Contact)
- 4 - Alarm Input (Dry Contact)
- 5 - Interlock (Dry Contact)
- 6 - AUTO/MANUAL Output (Relay Closure – NO/C/NC)
- 7 - Running Output (Relay Closure – NO/C/NC)
- 8 - Alarm Output (Relay Closure – NO/C/NC)

Wiring Diagram

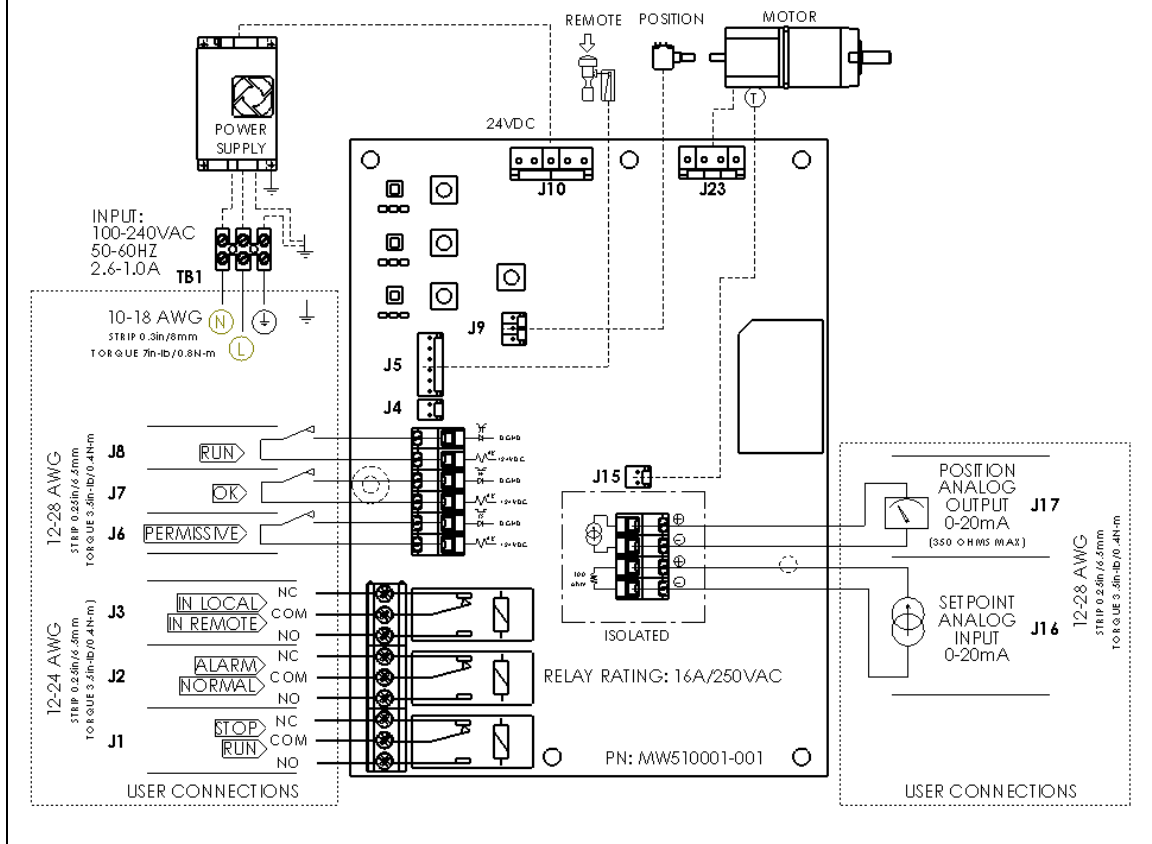

8.10.1 Analog Input (Current Loop)

The Analog Input is used for remote control of the pump flow. It accepts current inputs anywhere in the range of 0 to 22mA (e.g., 4-20mA) provided the “span” (the difference between the high and low value) is greater than 2mA. Use shielded cable (minimum 2-conductor with drain wire) for connection to the Analog Input. For example, 18AWG, 1-pair with drain (General Cable C8123.41.86). Remove approximately 0.25 inches, (6.5 mm) of insulation from the end of each conductor.

Identify terminal block J16 and the positive (+) and negative (-) labeled terminals (refer to the below photo):

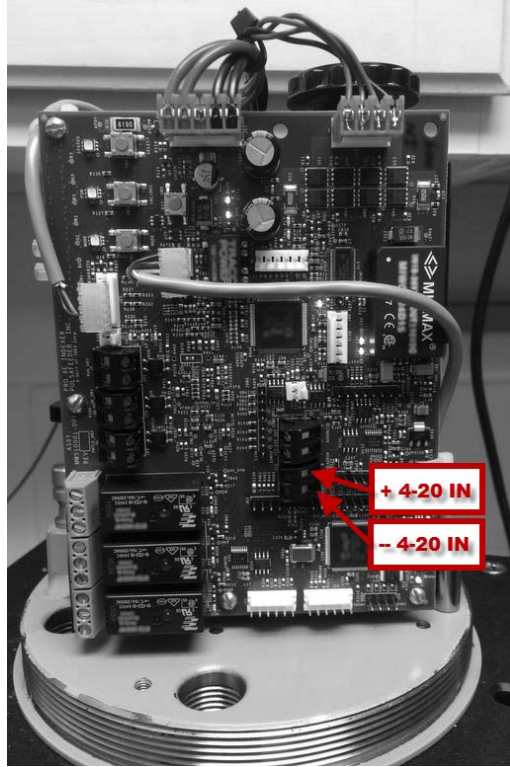

XAE Analog (4-20mA) Inputs

Loosen the terminal screws, and insert the stripped wire end fully into the terminal. Tighten the screw to 3.5 in-lbs. (0.4 Nm) to secure the conductor. Make certain that the terminal grips the wire, not the insulation.

The XAE will provide approximately 100 ohms of series resistance to a current loop. The Analog Input is electrically isolated from digital inputs, digital outputs and earth ground.



ANALOG INPUT AND ANALOG OUTPUT WIRING SHOULD HAVE A RATING OF AT LEAST 300 VOLTS AC (RMS) AND A TEMPERATURE RATING OF AT LEAST 75 DEGREES C.



IF STRIP LENGTH GUIDELINES IN ABOVE SECTIONS ARE NOT FOLLOWED, THERE IS A RISK OF ELECTRIC SHOCK AS WELL AS SHORTING OF ADJACENT CONNECTIONS GENERATING HAZARDOUS SPARKS.

8.10.2 Analog Output (Current Loop)

The Analog Output sends a signal representing the actual stroke length position. It can be adjusted to source current in the 0 to 25 mA range (4-20mA factory default). The output can also be set up for reverse-acting or split-ranging operation. The Current Output can be used to control slave devices e.g. XAE, or to fulfill closed loop system requirements.

Use shielded cable (minimum 2-conductor with drain wire) for connection to the Analog Input. For example, 18AWG, 1-pair with drain (General Cable C8123.41.86). Remove approximately 0.25 inches, (6.5 mm) of insulation from the end of each conductor.

Identify terminal block J17 and the positive (+) and negative (-) labeled terminals (refer to the below photo):

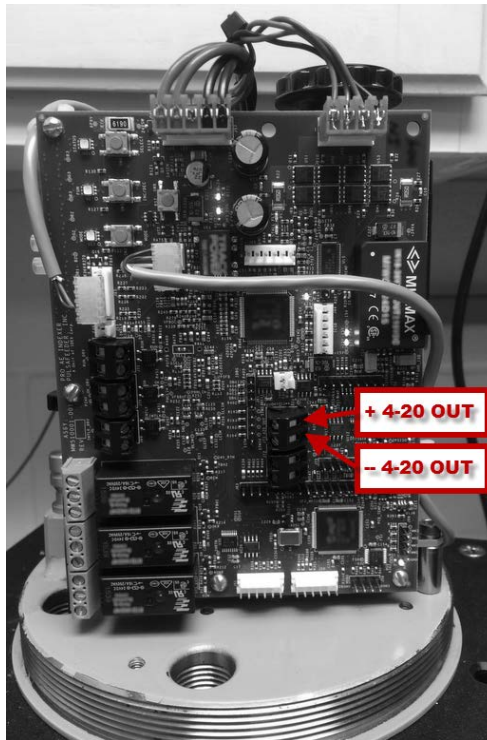

XAE Analog (4-20mA) Outputs

Loosen the terminal screws, and insert the stripped wire end fully into the terminal. Tighten the screw to 3.5 in-lbs. (0.4 Nm) to secure the conductor. Make certain that the terminal grips the wire, not the insulation.

Output will drive a maximum load of approximately 300 ohms of loop resistance. The Analog Output is electrically isolated from digital inputs, outputs, and earth ground.



ANALOG INPUT AND ANALOG OUTPUT WIRING SHOULD HAVE A RATING OF AT LEAST 300 VOLTS AC (RMS) AND A TEMPERATURE RATING OF AT LEAST 75 DEGREES C.



IF STRIP LENGTH GUIDELINES IN ABOVE SECTIONS ARE NOT FOLLOWED, THERE IS A RISK OF ELECTRIC SHOCK AS WELL AS SHORTING OF ADJACENT CONNECTIONS GENERATING HAZARDOUS SPARKS.

8.11 Dry Contact Inputs

Three Dry Contact Inputs are available on the XAE. They require a dry contact (switch) to activate. Three RED LED indicator lights are included to help tell when each input is closed.

8.11.1 RUN

The RUN input is designed to grant the actuator permission to control stroke length automatically. When activated (closed), the actuator will follow the analog input and adjust stroke length. When deactivated (open), the actuator will ignore the analog input.

The input is designed for a dry contact (switch) input. It must be an un-powered, dry contact only. When the contact is closed the actuator will be permitted to RUN.

Make connections to J8-1 and J8-2 as shown. The wire must be between 12 and 28 AWG (14 AWG recommended). The insulation should be stripped back approximately 0.25 inches (6.5mm).



12-28 AWG
STRIP 0.25in./6.5mm
TORQUE 3.5in-lb./0.4N-m

J8	RUN	[Terminal Diagram]
J7	OK	[Terminal Diagram]
J6	PERMISSIVE	[Terminal Diagram]

Location of RUN INPUT Indicating LED
LED turns RED when Input is Closed

Loosen the terminal screws, and insert the stripped wire end fully into the terminal. Tighten the screw to 3.5 in-lbs. (0.4 Nm) to secure the conductor. Make certain that the terminal grips the wire, not the insulation.



THE XAE IS SHIPPED FROM THE FACTORY WITH A JUMPER WIRE BETWEEN J8-1 AND J8-2. THIS SHOULD BE REPLACED A DRY CONTACT SWITCH TO ACTIVATE THE FUNCTION.

8.11.2 ALARM Input

The ALARM input is designed to pass local alarm information to the XAE's ALARM output. It does not stop XAE operation. To provide fail-safe operation the normal condition for the input is closed. An alarm condition is signaled when the input is opened. When the ALARM input is not used the input must be jumped.

The input is designed for a dry contact (switch) input. It must be an un-powered, dry contact only. When the contact is closed the condition is considered OK. When the contact is opened the condition is considered to be in ALARM.

Make connections to J7-1 and J7-2 as shown. The wire must be between 12 and 28 AWG (14 AWG recommended). The insulation should be stripped back approximately 0.25 inches (6.5mm).

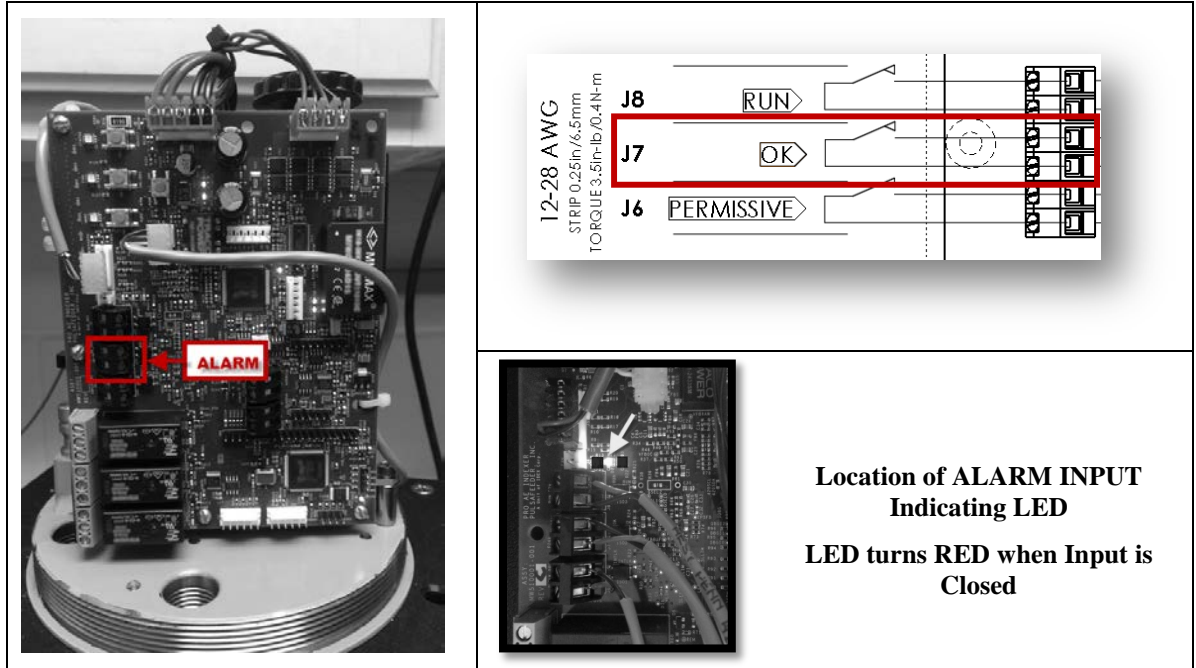

Loosen the terminal screws, and insert the stripped wire end fully into the terminal. Tighten the screw to 3.5 in-lbs. (0.4 Nm) to secure the conductor. Make certain that the terminal grips the wire, not the insulation.



THE XAE IS SHIPPED FROM THE FACTORY WITH A JUMPER WIRE BETWEEN J7-1 AND J7-2. THIS SHOULD BE REPLACED WITH A DRY CONTACT SWITCH TO ACTIVATE THE INTERLOCK FUNCTION.

8.11.3 PERMISSIVE INTERLOCK (RESET) INPUT

The INTERLOCK input is designed to grant the actuator permission to operate. The INTERLOCK must be activated (closed) for RUN and ALARM inputs to work. The INTERLOCK will also reset the XAE whenever it is enabled. This can be useful will reset the XAE - clearing any alarms present.



NOTE: THE RESET FUNCTION WILL DELAY OPERATION (THE ABILITY TO RESPOND TO A CONTROL SIGNAL) BY 10 SECONDS FROM THE TIME THE INTERLOCK INPUT IS CLOSED. FOR FASTER RESPONSE, USE THE RUN INPUT.

The input is designed for a dry contact (switch) input. It must be an un-powered, dry contact only. When the contact is closed the actuator will perform a Power-On-Reset before following the RUN and ALARM commands. When the contact is open the actuator will disable the drive motor and the RUN and ALARM relay outputs (the AUTO/MANUAL output will still reflect the status to the AUTO/MANUAL switch).

Make connections to J6-1 and J6-2 as shown. The wire must be between 12 and 28 AWG (14 AWG recommended). The insulation should be stripped back approximately 0.25 inches (6.5mm).

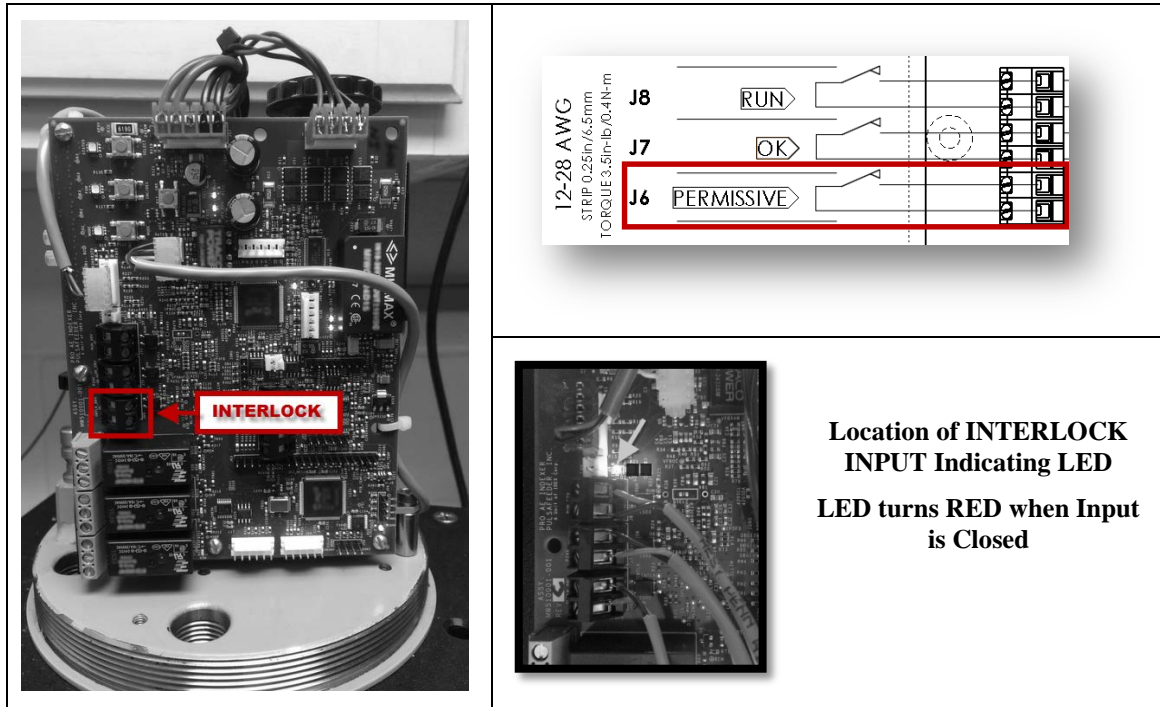

Loosen the terminal screws, and insert the stripped wire end fully into the terminal. Tighten the screw to 3.5 in-lbs. (0.4 Nm) to secure the conductor. Make certain that the terminal grips the wire, not the insulation.



THE XAE IS SHIPPED FROM THE FACTORY WITH A JUMPER WIRE BETWEEN J6-1 AND J6-2. THIS SHOULD BE REPLACED WITH A DRY CONTACT SWITCH TO ACTIVATE THE INTERLOCK FUNCTION.

8.12 OUTPUTS

Three Dry Contact Outputs are available on the XAE. Depending on the environment and loading they can be used to switch low and high voltage loads. Each output includes a RED indicator LED to help tell when the associated relay is turned on.

8.12.1 RUNNING OUTPUT

The RUNNING output signals when the XAE is operating normally by following an analog signal. To be in this state the following conditions must be met:

1. The AUTO/MANUAL must be in the AUTO position (pushed in)
2. The INTERLOCK input must be closed (through a jumper or external switch)
3. The RUN input must be closed (through a jumper or external switch)
4. A signal must be present on the 4-20mA input and the signal must be within the calibrated range
5. There must not be any fatal alarms (e.g., over temperature)

The output includes three relay contacts – the common, normally closed (closed when the output is disabled or the XAE does not have power, open when the output is enabled) and normally open (open when the output is disabled or the XAE does not have power, closed when the output is enabled).



THE RUN CONDITION IS SIGNALLED BY ACTIVATING THE OUTPUT RELAY THAT IS CONNECTED TO THE J1 TERMINAL BLOCK.

The output is rated at 16A/250VAC. It is not powered. It is not protected with a fuse or other device. The relay is not replaceable. When used to switch an AC line load, the circuit should be protected by external componentry – including a fuse and possibly a snubber for inductive loads (e.g., solenoid). When used to switch a DC load a fly back diode should be included.

Make connections to J1-1, 2 and 3 as shown. The wire must be between 12 and 24 AWG. The insulation should be stripped back approximately 0.25 inches (6.5mm).

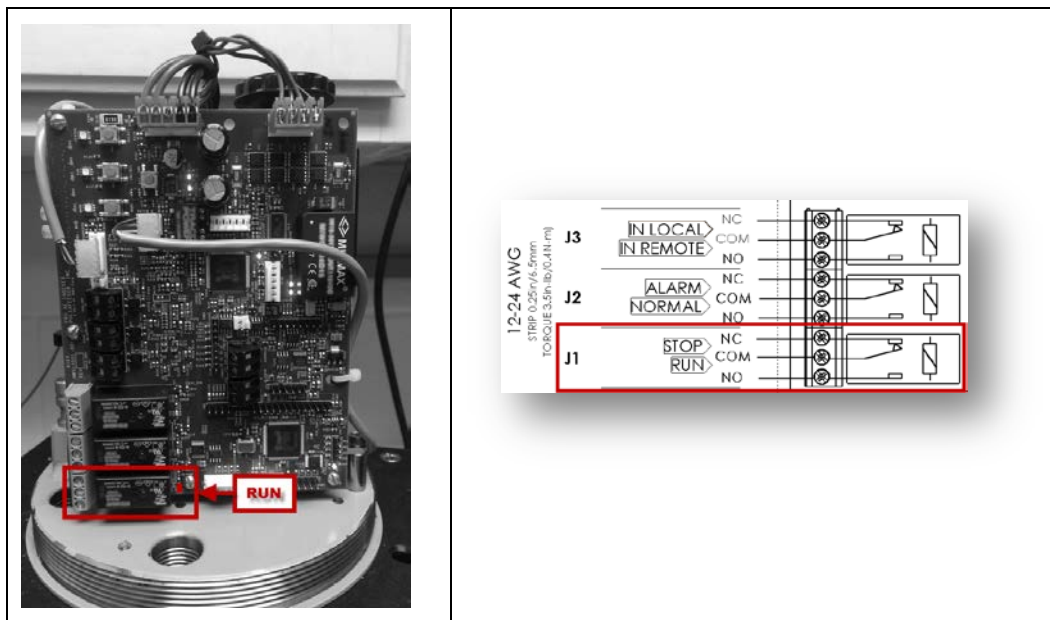

Loosen the terminal screws, and insert the stripped wire end fully into the terminal. Tighten the screw to 3.5 in-lbs. (0.4 Nm) to secure the conductor. Make certain that the terminal grips the wire, not the insulation.

The RED indicating LED next to the relay will turn on when the relay turns on (i.e., the XAE is RUN).

8.12.2 Alarm Output

The ALARM output signals when the XAE is experiencing an alarm. The Alarm can come from the Alarm input or be generated internally by the XAE. Please refer to the section TROUBLE CODES for more information.

The output includes three relay contacts – the common, normally closed (closed when the output is disabled or the XAE does not have power, open when the output is enabled) and normally open (open when the output is disabled or the XAE does not have power, closed when the output is enabled).



THE ALARM CONDITION IS SIGNALLED BY ACTIVATING THE OUTPUT RELAY THAT IS CONNECTED TO THE J2 TERMINAL BLOCK. THE ALARM RELAY IS DISABLED WHEN THE INTERLOCK IS DE-ACTIVATED.

The output is rated at 16A/250VAC. It is not powered. It is not protected with a fuse or other device. The relay is not replaceable. When used to switch an AC line load, the circuit should be protected by external componentry – including a fuse and possibly a snubber for inductive loads (e.g., solenoid). When used to switch a DC load a fly back diode should be included.

Make connections to J2-1, 2 and 3 as shown. The wire must be between 12 and 24 AWG. The insulation should be stripped back approximately 0.25 inches (6.5mm).

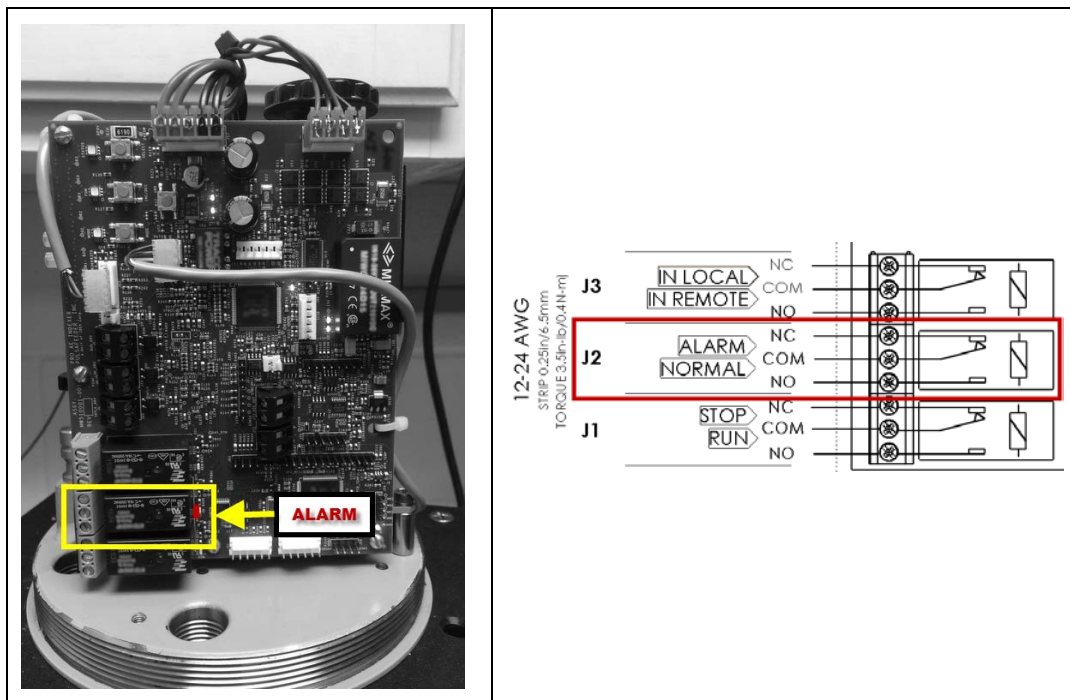

Loosen the terminal screws, and insert the stripped wire end fully into the terminal. Tighten the screw to 3.5 in-lbs. (0.4 Nm) to secure the conductor. Make certain that the terminal grips the wire, not the insulation.

The RED indicating LED will turn on when the relay turns on (i.e., the XAE is in ALARM).

8.12.3 AUTO/MANUAL Output

The AUTO/MANUAL output is designed to indicate when the AUTO/MANUAL switch on the XAE is in the MANUAL mode – that is not following a signal. The output includes three relay contacts – the common, normally closed (closed when the output is disabled or the XAE does not have power, open when the output is enabled) and normally open (open when the output is disabled or the XAE does not have power, closed when the output is enabled).

The XAE is in the MANUAL mode when the AUTO/MANUAL switch is pulled out:

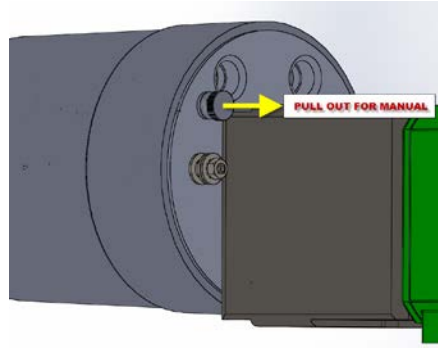

AUTO/MANUAL Switch



WHEN THE XAE IS IN MANUAL, IT CANNOT BE OPERATED FROM A REMOTE SOURCE.

WHEN IN THE MANUAL POSITION THE STROKE LENGTH CAN BE ADJUSTED USING THE MANUAL KNOB. PULL THE KNOB OUT TO ENGAGE THE CONNECTION TO THE XAE MOTOR AND ADJUST IT CLOCKWISE TO INCREASE THE SETTING AND COUNTER-CLOCKWISE TO DECREASE THE SETTING:

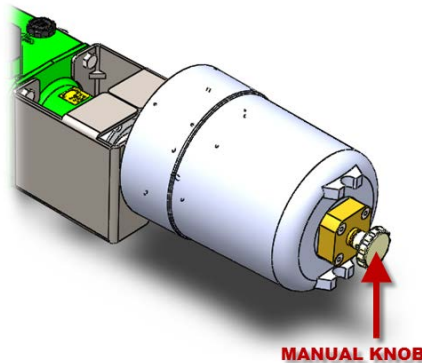

The MANUAL condition is signaled by activating the output relay that is connected to the J3 terminal block.

The output is rated at 16A/250VAC. It is not powered. It is not protected with a fuse or other device. The relay is not replaceable. When used to switch an AC line load, the circuit should be protected by external componentry – including a fuse and possibly a snubber for inductive loads (e.g., solenoid). When used to switch a DC load a fly back diode should be included.

Make connections to J3-1, 2 and 3 as shown. The wire must be between 12 and 24 AWG. The insulation should be stripped back approximately 0.25 inches (6.5mm).

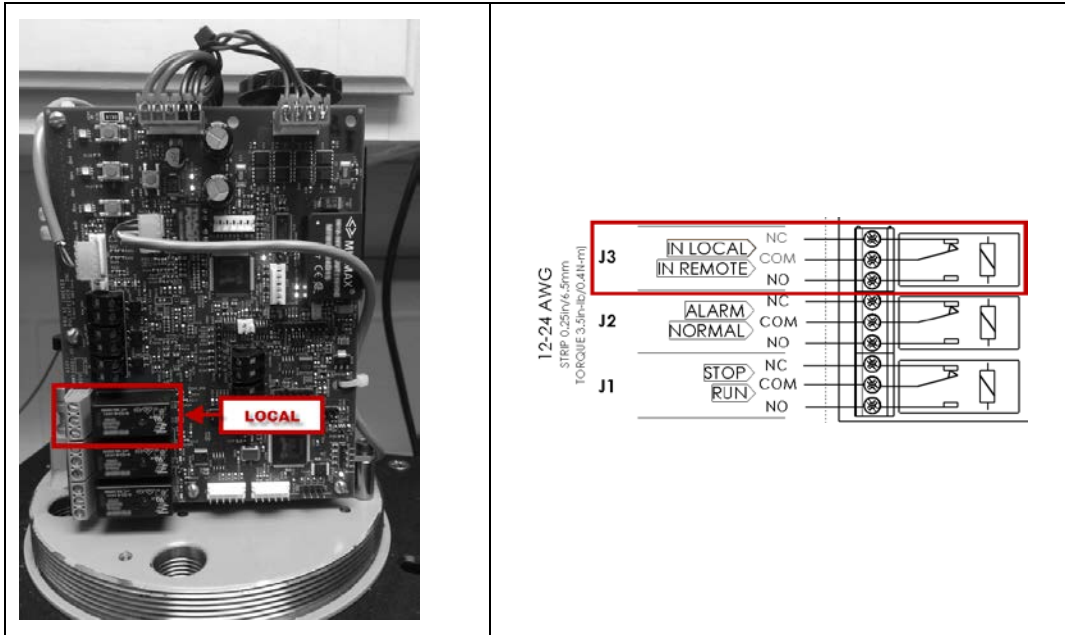

Loosen the terminal screws, and insert the stripped wire end fully into the terminal. Tighten the screw to 3.5 in-lbs. (0.4 Nm) to secure the conductor. Make certain that the terminal grips the wire, not the insulation.

The RED indicating LED will turn on when the relay turns on (i.e., the XAE is in MANUAL).

9. START-UP AND OPERATION

9.1 OVERVIEW

Once all electrical connections have been made, your XAE is ready for Start-up. The XAE is calibrated at the factory for 4-20mA input operation with the supplied pump. The following sections detail the procedures that can be used to configure and calibrate the XAE to meet the needs of the installation location.



DO NOT ATTEMPT TO REMOVE THE COVER OF THE XAE AND SET UP THE XAE IN A VERY WET OR RAINY ENVIRONMENT. WHILE CARE HAS BEEN TAKEN TO INSULATE POWER CONNECTIONS, DANGEROUS VOLTAGES ARE PRESENT AND CAN CAUSE ELECTRIC SHOCK, AND POSSIBLE ELECTROCUTION IF SAFETY PROCEDURES ARE NOT FOLLOWED

WHEN POWER IS SUPPLIED TO THE UNIT, LINE VOLTAGE MAY BE PRESENT WITHIN THE XAE ENCLOSURE EVEN WHEN THE MOTOR IS OFF.

DURING START-UP, IT MAY BE NECESSARY TO RUN THE PUMP MOTOR. THIS WILL CAUSE FLUID TO DISCHARGE FROM THE PUMP. YOU ARE RESPONSIBLE FOR SAFELY DIVERTING FLOW FROM THE PUMP DURING START-UP AND CALIBRATION.

THE XAE IS DESIGNED TO CONTROL THE PUMP STROKE LENGTH WITHIN THE PUMPS RATED PRESSURE AND FLOW. OPERATION BEYOND RATED SPECIFICATIONS, EVEN INTERMITTENTLY, MAY DAMAGE EQUIPMENT AND VOID THE WARRANTY.

IF THIS EQUIPMENT IS USED IN ANY MANNER NOT SPECIFIED BY PULSAFEEDER, PROTECTION PROVIDED BY THE EQUIPMENT MAY BE IMPAIRED.

9.2 USER INTERFACE

Calibration of the XAE is accomplished through a simple user interface that includes 4 buttons and 3 multi-color LED's. These are located at the end of the controller that is furthest away from the pump as shown below:

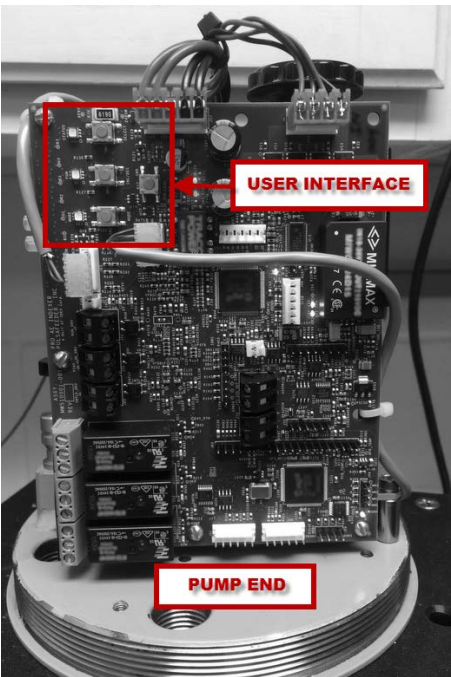
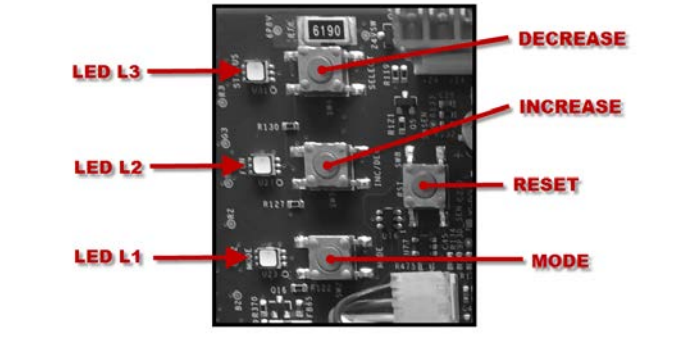
	<p style="text-align: center;">USER INTERFACE</p> 
<p>RESET: Resets (Re-Starts) the Board</p> <p>MODE: Selects the Calibration/Setting Mode</p> <p>INCREASE: Increases a setting or selects a high value</p> <p>DECREASE: Decreases a setting or selects a low value</p>	

9.3 SETUP & CALIBRATION



STATIC SENSITIVE PARTS ARE PRESENT ON THE CIRCUIT BOARD DURING THIS PROCEDURE. USE CAUTION WHILE PRESSING BUTTONS.

THIS PROCEDURE REQUIRES REMOVAL OF THE ENCLOSURE COVER. THIS PROCEDURE SHOULD BE PERFORMED ONLY IF THE AREA IS KNOWN TO BE SAFE FOR ELECTRONIC WORK.

Setup requires the XAE to be operated with the cover removed – exposing personnel to high voltages and parts that may start movement without warning. Setup must be performed by personnel that have read this document and are trained in the setup and configuration of electronic controls and electro-mechanical systems.

When powered the installer should avoid the incoming power termination points (TB1), the Power Supply (including open top and bottom), and the relay terminal points J1, J2 and J3 when used to switch hazardous voltages (e.g., 120VAC). These are depicted below:

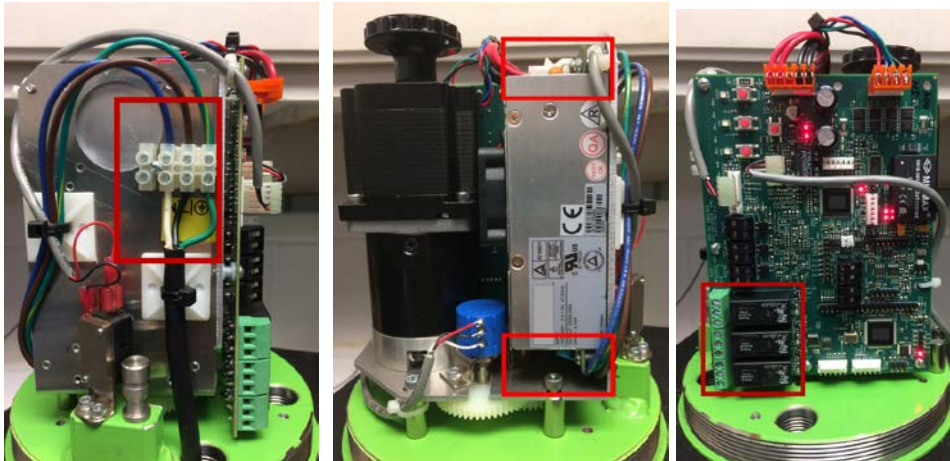

The main circuit board operates on 24VDC. Standard safety precautions should be taken in accordance with local regulations.

If the cover has not been removed follow the procedure under the COVER REMOVAL section in this document.

9.3.1 Analog Input Signal Calibration

The analog input signal should be user calibrated to each system. To perform a calibration, the signal-generating device (e.g., PLC) must be powered up, wired to the XAE and capable of altering its output from the minimum to the maximum signal. Refer to INSTALLATION AND WIRING-ANALOG INPUT for further details.

Note that the minimum span, or difference between low and high values, is 2.0 mA. The XAE will not attempt to change stroke length during this process.



THIS PROCEDURE REQUIRES OPERATION WHILE THE COVER IS REMOVED. THIS PROCEDURE SHOULD BE PERFORMED ONLY IF THE AREA IS KNOWN TO BE SAFE FOR ELECTRONIC WORK.

1. Move the AUTO/MANUAL switch to the MANUAL position.
2. Identify the hazardous locations to all personnel in the immediate area (see SETUP section in this document for further information). Assure the environment is safe.
3. Turn power on to the XAE. Wait of the system to boot and the L3 LED to come on BLUE (MANUAL MODE).



FOLLOW THE ANALOG INPUT CALIBRATION PROCEDURE OUTLINED IN APPENDIX.

9.3.2 Analog Output Signal Calibration



THIS PROCEDURE REQUIRES REMOVAL OF THE ENCLOSURE COVER. THIS SHOULD BE DONE ONLY IF THE AREA IS KNOWN TO SAFE FOR ELECTRONIC WORK.

To calibrate the analog output, attach a multi-meter set to read milliamps to the 4-20mA output circuit of the XAE. It is recommended that you calibrate the XAE analog output values to whatever is required by the equipment that will be using the signal – a PLC or DCS for example. The XAE will not actuate to change stroke length during this process.

1. Move the AUTO/MANUAL switch to the MANUAL position.
2. Identify the hazardous locations to all personnel in the immediate area (see SETUP section in this document for further information). Assure the environment is safe.
3. Turn power on to the XAE. Wait of the system to boot and the L3 LED to come on BLUE (MANUAL MODE).



FOLLOW THE ANALOG OUTPUT CALIBRATION PROCEDURE OUTLINED IN APPENDIX.

9.3.3 MECHANICAL CALIBRATION (0%/100%)



THIS PROCEDURE REQUIRES REMOVAL OF THE ENCLOSURE COVER. THIS SHOULD BE DONE ONLY IF THE AREA IS KNOWN TO BE SAFE FOR ELECTRONIC WORK.

Mechanical Calibration sets the mechanical position for the Minimum (0%) and Maximum (100%) pump settings. If the XAE was shipped with a pump attached, the mechanical calibration was performed at the factory and is typically not required. If the XAE was shipped without a pump attached, performing the mechanical calibration is mandatory for successful installation/operation.



BECAUSE THE STROKE ADJUSTMENT MECHANISM MOVES THE PUMP'S PISTON DURING ADJUSTMENT, IT IS POSSIBLE THAT FLUID WILL BE DISCHARGED BY THE PUMP. TAKE APPROPRIATE PRECAUTIONS.

1. Move the AUTO/MANUAL switch to the MANUAL position.
2. Identify the hazardous locations to all personnel in the immediate area (see SETUP section in this document for further information). Assure the environment is safe.
3. Turn power on to the XAE. Wait of the system to boot and the L3 LED to come on BLUE (MANUAL MODE).



FOLLOW THE MECHANICAL (0%/100%) CALIBRATION PROCEDURE OUTLINED IN APPENDIX.

10. ADVANCED PROCEDURE – ADDITION/REPLACEMENT OF XAE PULSA PRO PUMPS

When the XAE is added to a pump, it must be aligned to the pump before the two parts are coupled. This is done by setting the stroke length of the Pump to 50% and adjusting the XAE to 50% before coupling.

1. Set the pump stroke length to 50%. Prepare the XAE to operate un-coupled from the pump. Identify the output shaft and stay clear.
2. Move the AUTO/MANUAL switch to the MANUAL position.
3. Identify the hazardous locations to all personnel in the immediate area (see SETUP section in this document for further information). Assure the environment is safe.
4. Turn power on to the XAE. Wait of the system to boot and the L3 LED to come on BLUE (MANUAL MODE).
5. Follow the MECHANICAL (0%/100%) CALIBRATION procedure found in the Appendix. Stop after step #5.
6. Wait for the L2 and L3 LED's to turn on RED (the adjustment motor will stop).
7. The XAE is now at its 50% position. Remove power.
8. Align the pump stroke adjustment knob coupling to the XAE. If necessary, adjust the pump coupling (using the knob) up to ¼ of a turn to align the two coupling parts.

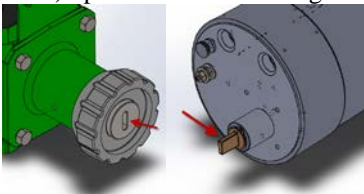

9. Remove 2 of 4 of the side cap bolts as shown below (7/16" for the 680-880, 5/8" for the 7120). Install the bracket half to the pump then to the XAE using the supplied hardware:

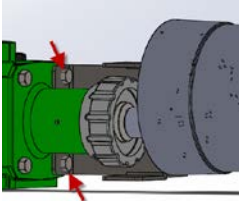

10. Install the second bracket half.

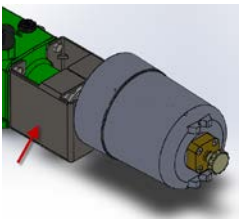

11. Apply power and complete the Mechanical Setup Procedure.

11. ADVANCED PROCEDURE – ADDITION/REPLACEMENT OF XAE PULSA SERIES 7120/7440/7660/8480 PUMPS

When the XAE is added or replace on a Pulsa Series 7120/7440/7660/8480, its output shaft must be aligned to the adjustment mechanism of the pump before the two parts are coupled. This is done by setting the stroke length of the Pump to 50% and adjusting the XAE to 50% before coupling.

Start Here - Cover Assembly Removal

1. Using the existing adjustment mechanism, adjust the pump stroke length to the indicated setting of 50%.



2. Identify the hazardous locations to all personnel in the immediate area (see SETUP section in this document for further information). Assure the environment is safe. Shutdown the pump. Lock-out/Tag-out the Pumping System to make it safe for the repair (e.g., consider electrical [disconnect], pressure [relieve/isolate], and pumped fluid [drain] hazards).
3. Remove the bleeder line that stretches across the top of the pump. Push in the collar and pull the tubing out of the fitting. Coil tubing at back of cover.

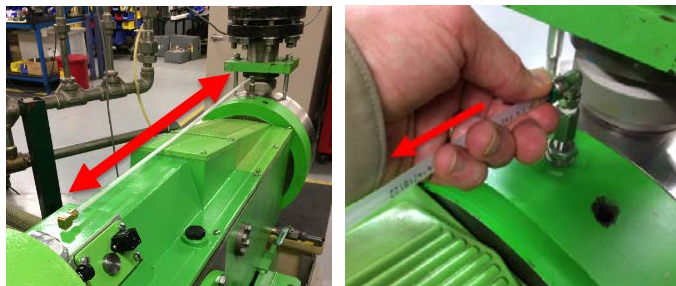

4. Remove the 4 screws that hold the forward access panel to the cover to expose the bevel gear and top of the oscillating housing.

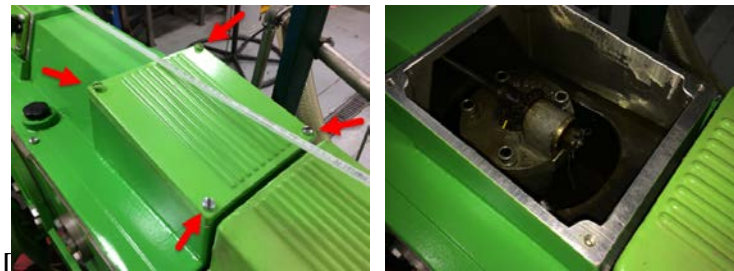

5. Make a note of the position of the control block by marking a tooth on the bevel gear and making an aligning mark on the housing. To keep the pump in calibration it is important to know where the 50% setting is during disassembly/re-assembly. Be sure that if you have to rotate any parts during assembly that you can return to this exact 50% position.

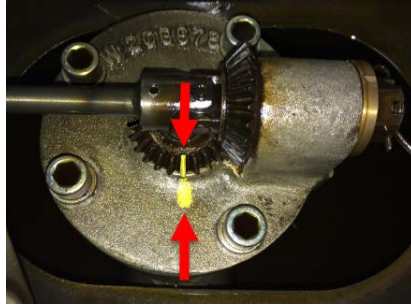

6. Locate the adjustment shaft assembly. One end of this shaft is square – it slips into the coupling in the front of the XAE. The other end of the shaft is round – it runs in a sleeve and drives a bevel gear in the oscillating housing.



7. Remove the cotter pin and castle nut from the round end of the old shaft (if it is still in place). Be careful not to drop these parts into the gear box as they will be difficult to retrieve.



8. Pull the brass washer off the end of the shaft (don't drop it).

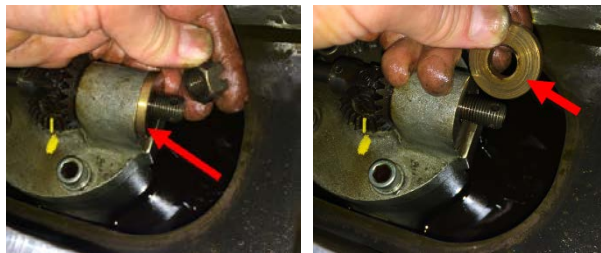

9. Disconnect the conduit connections to the existing controls.
10. Remove the oil level dip stick.



11. Remove the 5 of the 6 screws that hold the cover to the top of the pump. Leave one of the screws in the cover near the front. Loosen so that you can remove it with your fingers. The weight of the controller at the back of the cover will cause the cover to tip up off the top of the pump. Use this screw to control cover in the next several steps.

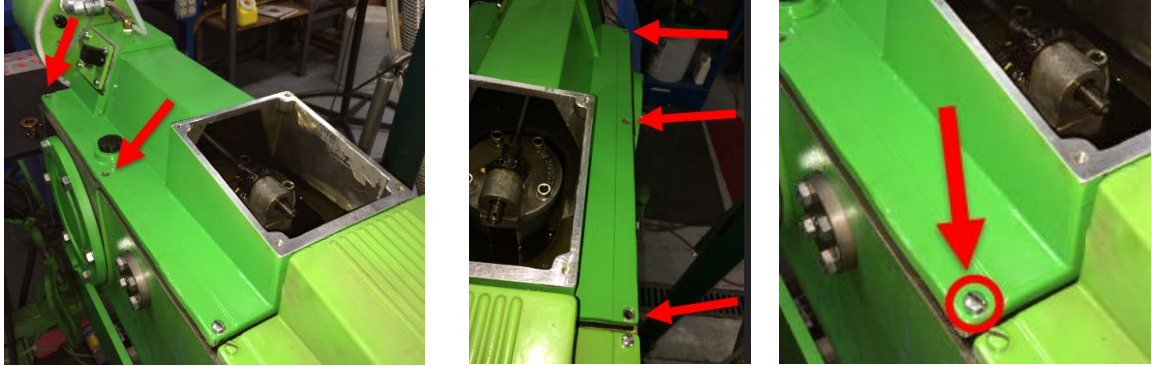

12. Use 2 people to remove the old cover assembly. The adjustment shaft is connected to the cover assembly, so when the cover is removed the shaft will come with it. Get one person ready to lift the control/cover assembly at the back of the pump while the second person will remove the last screw holding the cover on then pull the round end of the adjustment shaft out of the bearing and bevel gear (without dropping the bevel gear into the gearbox).

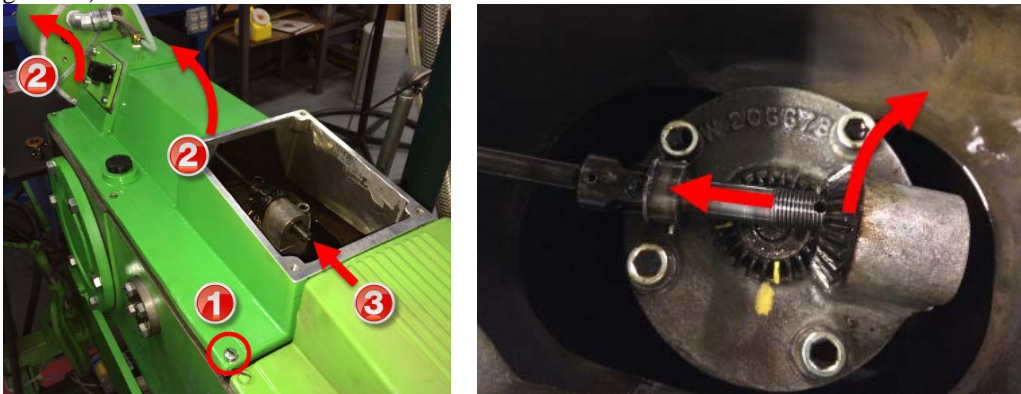

13. Continue with the next section if you will be replacing the XAE only. Otherwise skip the next section if you are replacing the complete cover assembly.

Cover Assembly Rework (Replacement of the XAE only)

Follow this section if you are reworking an existing cover assembly by replacing the XAE only. Skip this section if you are using a complete new XAE-Pump cover assembly.

14. Turn the pump cover assembly over to expose the bottom side.



15. Locate the (4) ¼-20 socket head cap screws that hold the existing XAE to the cover and remove them.

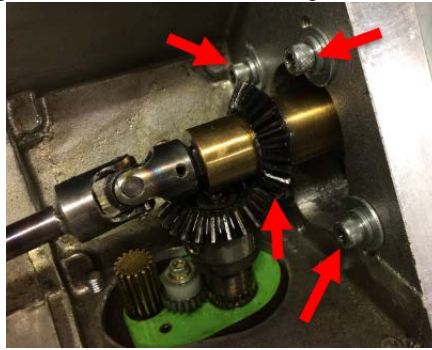

16. Slide the old actuator out of the cover mount. Depending on the condition of the old assembly, it may be necessary to feed the stroke adjustment rod through the hole in the cover to remove the assembly completely.
17. If the replacement XAE includes an adjustment rod it should be removed. Slide the square shaft from the XAE output coupling by pulling it straight out. Set it aside in a clean location.



18. Replace the (4) ¼-20 socket head cap screws to mount the new XAE onto the pump cover.
19. Turn the cover assembly face up.
20. Remove the XAE cover threading it off the back plate by turning it counter clockwise.
21. Install temporary power to the XAE (refer to section 8.8 Power Wiring).
22. Move the AUTO/MANUAL switch on the XAE to the MANUAL position (pulled out).
23. Turn power on to the XAE. Wait for the system to boot and the L3 LED's to come on BLUE (MANUAL MODE).
24. Follow the MECHANICAL (0%/100%) CALIBRATION procedure found in the Appendix. Stop after step #5.
25. Wait for the L2 and L3 LED's to turn on RED (the adjustment motor will stop).
26. The XAE is now at its 50% position. Turn off the XAE power and disconnect the temporary wiring.
27. Re-install the adjustment rod removed in step #17.
28. Proceed with the next section.

Cover Assembly Replacement

At this point a replacement Cover Assembly will be available (either a new replacement or an existing cover that has been reworked). The XAE will be mounted and calibrated so that it is adjusted to its 50% position and the mechanical indicator on the cover will show that setting.

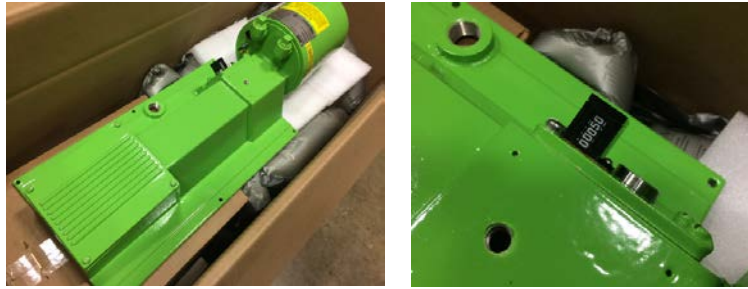

Note: New replacement cover assemblies are shipped from the factory with the XAE and indicator pre-set at 50%.

29. Prepare the replacement cover assembly for installation. First, if you have not already done so, remove the 4 screws that hold the front sub-cover to the top of the main cover. This will allow you to see the bevel gear on top of the oscillating housing assembly.

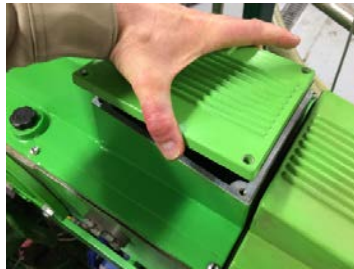

30. If a replacement oscillating housing assembly for the pump was supplied with the new cover assembly:
- Make a note of the position of the control block by marking a tooth on the bevel gear and making an aligning mark on the housing (see step #5).
 - Remove the cotter pin and castle nut from the round end of the new shaft (see step #7).
 - Pull the brass washer off the end of the shaft (see step #8).
 - Pull the round shaft out of the bearing on top of the oscillating housing (see step #12).
 - Pull the shaft gear out of the bevel gear.
 - Keep these parts in a clean location as you will need them at a later step.
 - Replace the oscillating housing in the pump. Set the oscillating housing at its 50% point. Note this step is beyond the scope of this procedure. Contact Technical Services if further guidance is required.
31. Go to the pump assembly. Apply general purpose grease to the bevel gear, bearing bore, and both sides of the bearing block (where the bevel gear and brass washer sit) on the oscillating housing before assembly.



32. Go back to the cover assembly. On the XAE the square end of the adjustment shaft can easily pull out of the coupling of the controller – so you will need to be careful while handling it so it doesn't fall out and doesn't rotate.
33. Use 2 people to install the cover assembly. One person will lift the cover assembly and the second person will help line it up with the pump. The second person will also guide the round end of the adjustment shaft through

the bevel gear and the bearing. Note - you will need to mesh the bevel gears and align the cross pin with the slot in the gear as you insert the shaft.

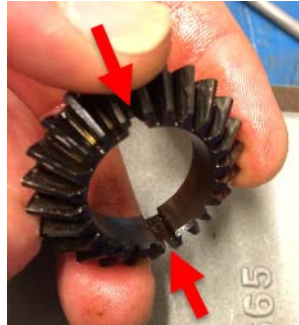
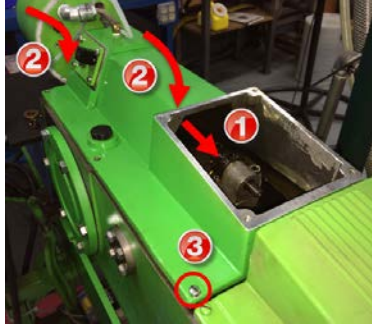

34. Install the (6) cover screws finger tight.
35. Grease and replace the Brass washer, and castle nut. Tighten the nut by hand to take up the slop in the shaft then loosen by one slot position to align the slots in the nut with the hole in the shaft. The shaft needs to turn freely in the bearing. Install the cotter pin and spread the end.

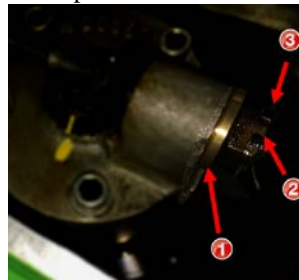

36. Remove the XAE cover threading it off the back plate by turning it counter clockwise.
37. Replace the conduit and power and signal wiring (refer to section 8.8 Power Wiring).
38. Move the AUTO/MANUAL switch on the XAE to the MANUAL position.
39. Identify the hazardous locations to all personnel in the immediate area (see SETUP section in this document for further information). Assure the environment is safe.
40. Turn power on to the XAE. Wait for the system to boot and the L3 LED's to come on BLUE (MANUAL MODE).
41. Complete Analog Input / Analog Output calibration as required. Note – AUTO/MANUAL switch will need to be positioned in the AUTO setting (pushed in) to follow the signal.
42. Applying 4-20mA a signal, exercise the actuator between the 0% and 100% position. If the XAE does not achieve the 0% and 100% positions, follow the MECHANICAL (0%/100%) CALIBRATION procedure found in the Appendix. The procedure includes pictures of the PalsaPro (on the left below) – these should be ignored. Instead, refer to the dial indicator (on the right below) on the cover assembly for the actual 0% and 100% positions.

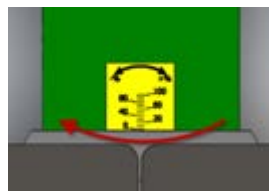

43. Remove power and replace the XAE cover. Tighten it onto the back plate so that it is tight to the flange.
44. Replace all covers/sub-covers removed in the above procedure (e.g., the front sub cover).

45. Hand tighten all screws.
46. Extend the bleeder line from the bleeder at the front of the pump to the fitting in the cover at the back of the pump.
47. The pump/control is now ready to return to service.

Trouble Shooting Replacement XAE

Condition: XAE is jammed (will not turn under its own power) near the 0% or 100% position. Or, XAE cannot achieve 0% or 100% position.

Cause: Block in oscillating housing it jammed against hard mechanical stop. Indicator needs to be re-calibrated to represent true position.

Remedy #1: When jammed so that it cannot move it is necessary release the the mechanism:

1. Loosen the 4 socket head cap screws that hold the cap on the oscillating housing (remove front sub-cover to access these screws).

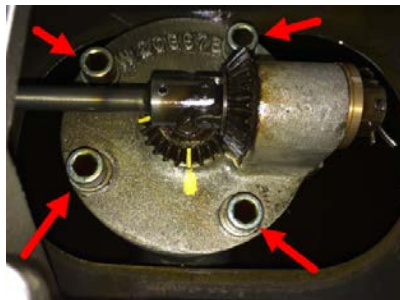

2. Adjust the stroke length by hand using the manual adjustment knob in the XAE cover in the direction away from the jam. For example, if jammed at 98% indicated on the dial, adjust the position towards 90%.



3. The adjustment should turn freely. If not, repeat 1 and 2 above.
4. Re-tighten the 4 screws evenly.
5. Continue with Remedy #2.

Remedy #2: When the XAE cannot move to position (and that position cannot be achieved by hand) it typically means that there is a mis-match between the position of the block in the oscillating housing and the stroke indicator.

1. Remove the front sub-cover to view the oscillating housing.
2. Using the XAE and an external signal generator (4-20mA) or the manual adjustment knob, adjust the XAE near the 0% position but not such that it can become jammed. For example, if it stops at 3% on the dial indicator then adjust it to 5%.
3. Place the AUTO/MANUAL switch in the MANUAL position (pull it out).
4. Adjust the setting using the manual control until it stops.
5. Rotate the manual adjustment knob in the opposite direction 38 turns (about 1.5 turns of the bevel gear on the top of the oscillating housing). This is the zero position of the control block in the oscillating housing.
6. Remove the stroke setting indicator from the side of the cover assembly by removing the 4 screws and pulling straight away from the side of the cover.

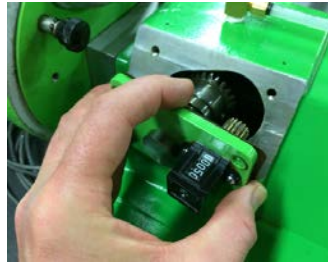

7. Turn the brass gear on the dial indicator until the dial reads 0000.



8. Replace the stroke setting indicator in the cover.
9. Replace the 4 retaining screws and tighten by hand.
10. Remove power from the XAE and remove the cover loosening it from the back plate by turning counter clockwise.
11. Follow the MECHANICAL (0%/100%) CALIBRATION procedure found in the Appendix. The procedure includes pictures of the PalsaPro – these should be ignored. Instead, refer to the dial indicator on the cover assembly for the actual 0% and 100% positions.
12. Remove power and replace the XAE cover tightening it onto the back plate so that it is tight to the flange.
13. Replace all covers/sub-covers removed in the above procedure (e.g., the front sub cover).
14. Hand tighten all screws.
15. Restore power. Retest.

12. FACTORY RE-INITIALIZATION



THIS PROCEDURE REQUIRES REMOVAL OF THE ENCLOSURE COVER. THIS SHOULD BE DONE ONLY IF THE AREA IS KNOWN TO BE SAFE FOR ELECTRONIC WORK.

A Factory Re-initialization sets all calibration settings to their factory values and is typically not required. The user also needs to keep in mind that once the Factory Re-Initialization is performed, all user calibrations are erased. This procedure should be performed only if the user has reason to believe that the internal XAE memory has become corrupted. Memory Corruption usually manifests itself with inconsistent or erratic operation. A number of factors could cause memory value corruption including:

1. Disregard of electrostatic precautions during installation,
2. Improper wiring,
3. Voltage surges, spikes, etc.

The pump MUST be running during this process to ensure an accurate zero position is obtained. Therefore you MUST ensure it is safe to operate the pump during the procedure.

1. Verify that power to the XAE is off and the environment is safe for open operation.
2. Remove the enclosure cover.
3. Press and hold the MODE button while applying power to the XAE.

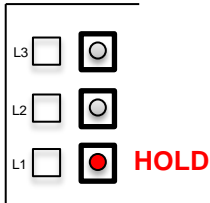

4. Continue to hold the MODE button until LED's L1 (BLUE), L2 (GREEN) and L3 (RED) turn on.

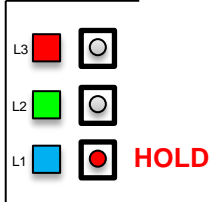

5. Release the MODE button.
6. The LED's flash BLUE while the factory calibration values are restored.

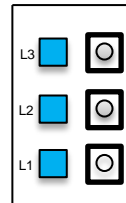

7. Perform any additional calibration procedures as required.
8. Remove Power to the XAE. Replace the cover and return power to restore normal operation.

13. DIAGNOSTICS

13.1 TROUBLE CODE REPORTING

The XAE is designed to be as fault-tolerant and self-recovering as possible. When the XAE encounters an abnormal condition, a trouble code is indicated by blinking 2 LED's on the XAE main board (labeled L2 and L3), internal to the enclosure.

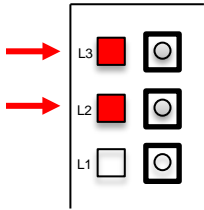

Trouble Messaging

The standard Trouble code is indicated as follows:

- Both the L2 and L3 LED's will blink once at a slow rate in the color RED.
- The L2 LED will blink a number of times at a fast rate to indicate the first trouble code digit (e.g., 1).
- The L3 LED will blink a number of times at a fast rate indicate the second trouble code digit (e.g., 2).

To display this in the form of a picture (example Error Code 13):

	L1	L2	L3
START	<input type="checkbox"/>	<input type="checkbox"/>	<input type="checkbox"/>
BEGIN ERROR MESSAGE	<input type="checkbox"/>	<input checked="" type="checkbox"/>	<input checked="" type="checkbox"/>
1 st POSITION FLASH 1X	<input type="checkbox"/>	<input checked="" type="checkbox"/>	<input type="checkbox"/>
2 nd POSITION FLASH 1...	<input type="checkbox"/>	<input type="checkbox"/>	<input checked="" type="checkbox"/>
2 nd POSITION FLASH 2...	<input type="checkbox"/>	<input type="checkbox"/>	<input checked="" type="checkbox"/>
2 nd POSITION FLASH 3...	<input type="checkbox"/>	<input type="checkbox"/>	<input checked="" type="checkbox"/>
RECYCLE TO START	<input type="checkbox"/>	<input type="checkbox"/>	<input type="checkbox"/>

This sequence will repeat until the trouble condition is cleared – either automatically, or through corrective action.

13.1.1 Trouble Code Table

Please refer to the following table for Trouble Codes, Alarm Relay activation, and Corrective Action:

Code	Definition	Description	Alarm Relay	Stop?	Corrective Action
11	Feedback Error	The output shaft position measurement is out of range or unstable.	YES	YES	<ul style="list-style-type: none"> • Reset Actuator • Check Connection to J9 on Circuit Board • Perform mechanical calibration
12	Position Error	Failure to reach the commanded position within the timeout period (5 minutes). After 10 minutes the error will clear and the controller will automatically retry the position adjustment.	YES	YES	<ul style="list-style-type: none"> • Check pump for over travel (jamming) near end stops (0% and 100%). • Decouple and assure free operation of pump adjustment mechanism. • Perform mechanical calibration.
13	Temperature Error	The motor temperature measurement device is out of range	YES	YES	<ul style="list-style-type: none"> • Check connection on J15 • Reset Actuator • Replace component
14	Over Temperature	The motor temperature is High - above 90C (194F). The motor will stop until the temperature drops below 80C (176F). The error will clear automatically.	YES	YES	<ul style="list-style-type: none"> • Check ambient temperature • Shield from radiated heat (sun/motor/other equipment) • Check pump gearbox temperature (gear oil lubricant level) • Check pump motor temperature – repair or shield • Check pump operating conditions (pressure)
15	Signal Error	The Analog Input Signal is outside the calibration range by more than 0.5mA.	YES	NO	<ul style="list-style-type: none"> • Correct Signal • Check wiring • Check connection to J16 • Check polarity + and – on J16 • Re-Calibrate analog input
21	0% End-Stop Error	The actuator is attempting to adjust below its allowed low limit (0%)	NO	YES	<ul style="list-style-type: none"> • Perform Mechanical Calibration (coupled) • Follow procedure to re-couple Actuator to pump
22	100% End-Stop Error	The actuator is attempting to adjust above its allowed high limit (100%)	NO	YES	<ul style="list-style-type: none"> • Perform Mechanical Calibration (coupled) • Follow procedure to re-couple Actuator to pump

ALARM RELAY: The alarm relay will activate during presence of the condition.

STOP?: Operation of the unit will be inhibited until the problem is corrected.

13.2 POWER-ON-SELF TEST

Upon application of input power, the XAE will perform a power on self-test and indicate status as follows:

IDENTIFICATION	STATUS
L1 (BLUE), L2 (BLUE), L3 (BLUE) turn on at the same time and stay on for approximately 2 seconds.	Normal Power Up, using User Calibration Values.
L1 (GREEN), L2 (GREEN), L3 (GREEN) turn on at the same time and stay on for approximately 2 seconds.	Abnormal Power Up – User Calibration Values missing. Copying Factory Values to User Values.
L1 (RED), L2 (RED), L3 (RED) turn on at the same time and stay on for approximately 2 seconds.	Abnormal Power Up – User and Factory Values missing/corrupted. Copying Defaults to Factory Values.

13.3 DIAGNOSTIC LED'S

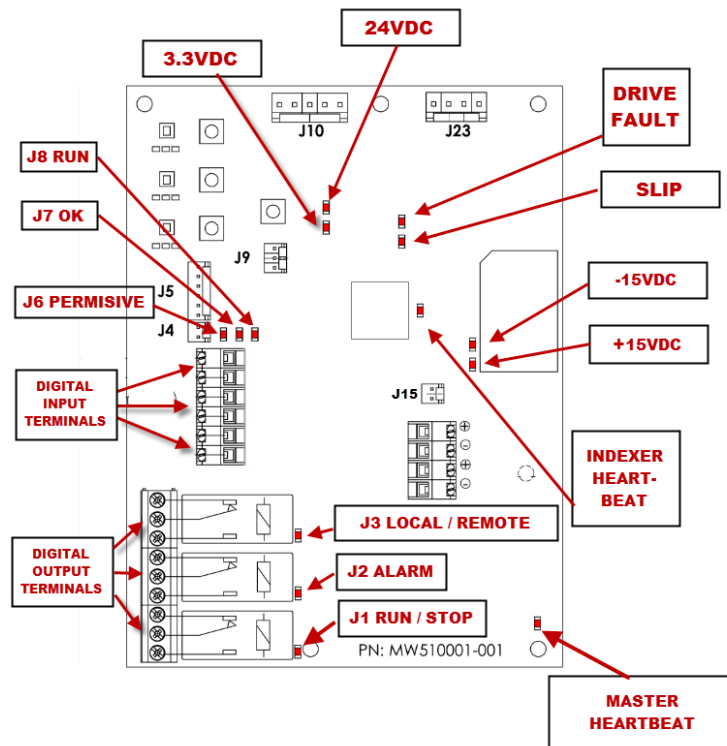

LED	Function	Normal Operation	Abnormal Operation
24 VDC	24 VDC Power Supply Health	On	Off
3.3 VDC	3.3 VDC Power Supply Health	On	Off
Drive Fault		Off	On
Slip		Off	On*
-15 VDC	-15 VDC Power Supply Health	On	Off
+15 VDC	+15 VDC Power Supply Health	On	Off
Indexer Heart Beat	Motor Control	Flash	Off
Master Heart Beat		Flash	
Output Relay J3	When the XAE is in MANUAL	On	
Output Relay J2	When the XAE is in ALARM	On	
Output Relay J1	When the XAE is in RUN	On	
Digital Input J8	When closed the XAE is permitted to RUN	On	
Digital Input J7	When closed the XAE is OK	On	
Digital Input J6	When closed the XAE is ENABLED	On	

* Slip Detection may turn on at slow speeds and when stopped. This is normal.

13.4 ERROR RECOVERY

In cases of abnormal operation, the following procedure is recommended:

1. First, check all power and process connections to ensure all wiring is secure and properly connected.
2. Check the internal connections within the XAE.
3. Ensure that the cable connections to J5, J9, J10, J15 and J23 are secure and seated properly.
4. Perform the procedure found under the FACTORY RE-INITIALIZATION section.
5. If necessary, perform a new Analog Input signal calibration.
6. If necessary, perform a new Analog Output signal calibration.
7. If necessary, perform a new Mechanical calibration.

14. SPECIFICATIONS

Input Power	100-240 VAC, 50/60 Hz, 1 phase $\pm 10\%$ (standard) 2.5A (115 VAC) / 1.24A (230 VAC) 200W
--------------------	--

Stroke Length Control	0 – 100% control range Resolution – 0.0625%
------------------------------	--

Stroke Adjustment response	Approximately 1.5% per second (pump model dependent)
-----------------------------------	--

Analog Input	
Operating Range	0 to 24mA (4-20 mA factory default)
Input Impedance	100 ohms
Minimum Span	2.0 mA
Isolation	500V from all other inputs, outputs and ground, optically isolated
Conditioning	8 second running average. Split Ranging and Reverse Acting accessible via calibration.

Analog Output	
Operating Range	0 to 22mA (4-20 mA factory default)
Maximum Load	300 ohms
Minimum Span	2.0 mA
Conditioning	None. Output represents current stroke position. Split Ranging and Reverse Acting accessible via calibration.
Isolation	500V from all other inputs, outputs and ground, optically isolated.

Digital Input	
RUN	Optically isolated dry contact input. BV = 3750Vrms, 24VDC, 3mA
ALARM	Optically isolated dry contact input. BV = 3750Vrms, 24VDC, 3mA
INTERLOCK	Optically isolated dry contact input. BV = 3750Vrms, 24VDC, 3mA

Relay Output	
RUN	Form C Relay, Reinforced Insulation 5A/120-240VAC/24VDC
ALARM	Form C Relay, Reinforced Insulation 5A/120-240VAC/24VDC
AUTO/MANUAL	Form C Relay, Reinforced Insulation 5A/120-240VAC/24VDC

Environmental	
Rated Ambient Temperature	Standard: -20°C to 50°C (-4°F to 122°F) Extended: -40°C to 70°C (-40°F to 158°F)
Storage Ambient Temperature	-40°C to 85°C (-40°F to 185°F)
Enclosure	NEMA 4X, NEMA 7
Approvals	Enclosure Only: UL 1203 / CSA 22.2, NEMA 4X, NEMA 7
Transient Voltage	Input to Output: 4000V, Input to Ground: 1400VAC, Output to Ground: 1500VAC
Voltage Overload	120% Continuous,
Pollution Degree	Suitable for Pollution Degree 2
Input Voltage	90-264 VAC, Single phase input, 47-63 Hz
Altitude	3300 Ft (1000 M) above sea level (de-rate 5% per additional 3300 Ft)
Humidity	0-90% (non-condensing)
Temperature	-40°C (-40° F) Minimum operating temperature (unit must start at 0°C, and be powered continuously) +50° C (122° F) Max (Standard Construction) +70° C (158° F) Max (High Temp Construction)
Earth Leakage Current	Size Earth Leakage Circuit Breakers (ELCB) to a detection level of 1mA or greater
Fuse	Un –fused. Installer to provide over current protection (fuse) of input. Power supply output is short circuit protected.

15. WIRING DIAGRAM

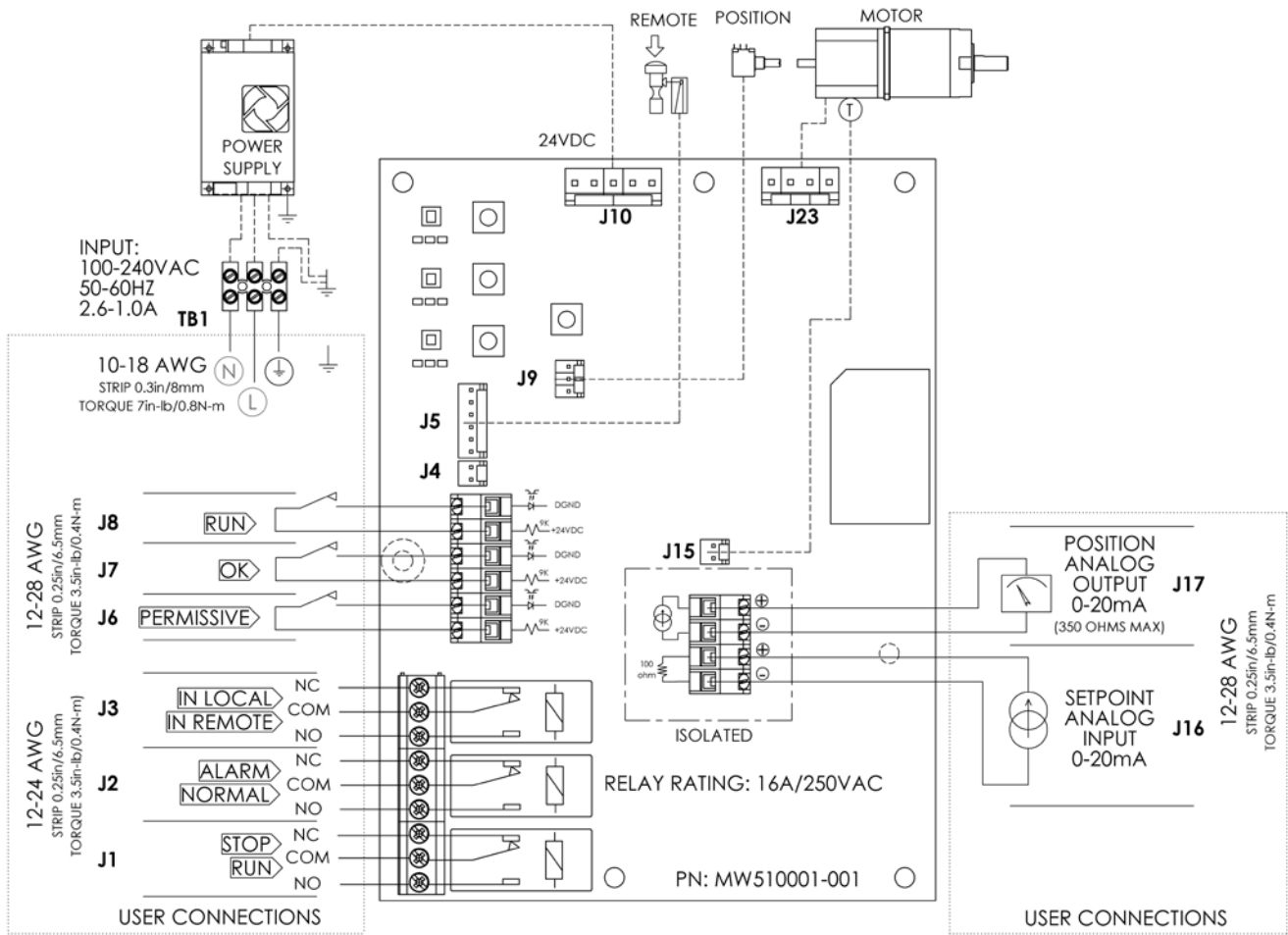

16. FIELD WIRING SUMMARY

CONNECTOR LOCATION		FUNCTION/CONNECTION	REFERENCE SECTION
TB1	Neutral (N)	Neutral connection 100-240VAC, 50/60Hz	Electrical Wiring
	Line (L)	Line connection 100-240VAC, 50/60Hz	Electrical Wiring
	Ground	Earth Ground connection 100-240VAC, 50/60Hz	Electrical Wiring
J1	Position 1 (NC)	RUN Indication - Normally Closed Dry Contact Output Connection	Outputs
	Position 2 (COM)	RUN Indication - Common Contact Output Connection	Outputs
	Position 3 (NO)	RUN Indication - Normally Open Contact Output Connection	Outputs
J2	Position 1 (NC)	ALARM Indication - Normally Closed Dry Contact Output Connection	Outputs
	Position 2 (COM)	ALARM Indication - Common Contact Output Connection	Outputs
	Position 3 (NO)	ALARM Indication - Normally Open Contact Output Connection	Outputs
J3	Position 1 (NC)	MANUAL Indication - Normally Closed Dry Contact Output Connection	Outputs
	Position 2 (COM)	MANUAL Indication - Common Contact Output Connection	Outputs
	Position 3 (NO)	MANUAL Indication - Normally Open Contact Output Connection	Outputs
J6	Position 1 (V+)	INTERLOCK – Voltage supply to Dry Contact	Inputs
	Position 2 (SEN)	INTERLOCK – Sense of +24V from Contact	Inputs
J7	Position 1 (V+)	ALARM – Voltage supply to Dry Contact	Inputs
	Position 2 (SEN)	ALARM – Sense of +24V from Contact	Inputs
J8	Position 1 (V+)	RUN – Voltage supply to Dry Contact	Inputs
	Position 2 (SEN)	RUN – Sense of +24V from Contact	Inputs
J16	Position 1 (-)	0-20mA Input (-)	Inputs
	Position 2 (+)	0-20mA Input (+)	Inputs
J17	Position 1 (-)	0-20mA Output (-)	Outputs
	Position 2 (+)	0-20mA Output (+)	Outputs

17. TROUBLESHOOTING GUIDE

PROBLEM	POTENTIAL CAUSE	SOLUTION
INTERNAL LED DISPLAY		
No LED Display	No power supplied	Check power source plug & circuit breaker
	Supply power wired incorrectly	Check wiring
	Supply power outside of specification	Check voltage/ frequency against specification
LED's are flashing	Normal at startup	See Start-up & Operation section
	Indicates operation fault	See table in Diagnostics Trouble Code section for LED blink codes
POWER		
No power	No power supplied	Check power source. Plug & Circuit Breaker
Indicators	Supply power wired incorrectly	Check wiring
	Supply power outside of specification	Check voltage/frequency against specification
MOTOR		
Motor not working/ No stroke control	No power supplied	Check power source. Plug & Circuit Breaker
	Damaged electronics or motor	Call field service

18. MAINTENANCE & SPARE PARTS



ALL MAINTENANCE WORK MUST BE CARRIED OUT ONLY WHEN THE XAE AND CONNECTED EQUIPMENT IS STOPPED AND DISCONNECTED FROM MAINS SUPPLY (INCLUDING AUXILIARY CIRCUITS). MAINTAINING ORIGINAL CHARACTERISTICS OVER TIME MUST BE ENSURED BY AN EFFICIENT MAINTENANCE AND INSPECTION PLAN, DEVELOPED AND MANAGED BY QUALIFIED TECHNICIANS, TAKING INTO ACCOUNT THE SERVICE AND THE ACTUAL ENVIRONMENTAL CONDITIONS IN WHICH IT OPERATES.



17.1 OPERATING PRECAUTIONS

All operations must be performed by qualified personnel.

Work on the unit should only be performed with safety supervisor authorization, after having verified that:

- A. Disconnect power at the source (follow your local lockout tag out procedures)
- B. The power line is disconnected and no parts are energized, including any auxiliaries
- C. Ensure that any risk of accidental restart has been excluded
- D. Consult Manufacturers Operating Manual(s) for instructions on minimizing risk due to pressurized or chemically dangerous conditions within the system
- E. With equipment switched off, that the ON-OFF valves on the suction and discharge pipelines are closed.
- F. Equipment has been adequately cleaned, when operating in environments exposed to aggressive chemicals.
- G. Maintenance personnel shall refer to the Installation & Wiring Instruction section for safe return to service after repair.

Since the machine object of supply is a product designed and intended for operation in industrial areas, additional measures must be adopted and assured by the person responsible for the installation, should more restrictive safety conditions be required.



17.2 CLEANING AND DECONTAMINATION

The XAE enclosure may be cleaned with water and mild detergent. Decontamination shall occur when the XAE is exposed to a release of process chemicals. Follow the SDS for clean-up in the event of a chemical spill.

17.3 USER REPLACEABLE PARTS FOR THE XAE

MFG & MFG P/N	DESCRIPTION
MW510001-001	BOARD ASSY, MASTER/INDEXER, XAE
MW530002-000	POWER SUPPLY, 200W, 24VDC, 120-240VAC, 50/60Hz
MW510001-000	GEAR MOTOR ASSEMBLY
MW520001-000	TB1 TERMINAL BLOCK
MW530006-000	TEMPERATURE SENSOR, MOTOR
MW260005-000	KNOB, MANUAL ADJUSTMENT
W206894-000	KNOB, AUTO/MANUAL SWITCH
W215008-NTR	GASKET, COVER

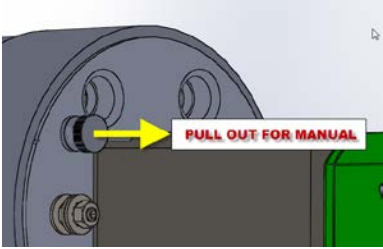
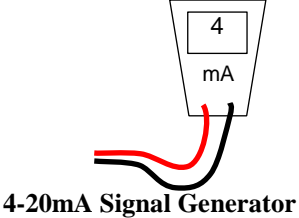
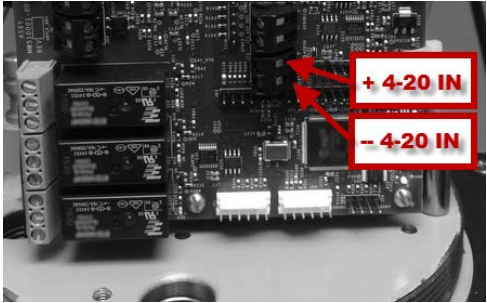
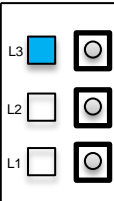
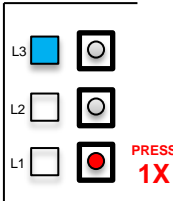
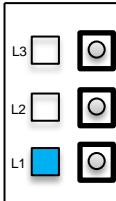
19. APPENDIX

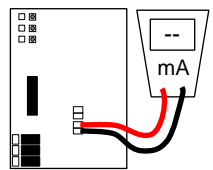
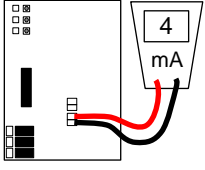
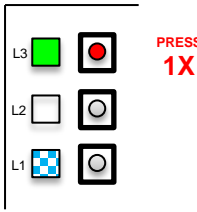
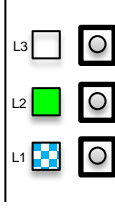
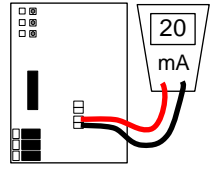
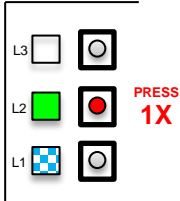
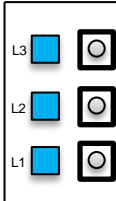
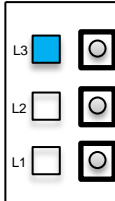
ANALOG INPUT CALIBRATION			
SET MANUAL MODE	EQUIPMENT	CONNECTION	
			
CALIBRATE - ANALOG INPUT (4-20mA) [STROKE WILL NOT ADJUST]			
			
1) Power On, set MANUAL, wait for L3 to turn on (BLUE).	2) Press and release MODE 1 time to select 4-20 input cal.	3) LED L1 turns on (BLUE). Wait for L1 to flash.	4) LED L1 flashes. L3 turns on to signal Low point cal.
			
5) Attach signal generator to J16-1 (-) and J16-2 (+).	6) Set signal generator to low signal (e.g., 4mA). Wait 2 seconds.	7) Press and release LOW 1 time to save the Low point.	8) LED L1 flashes. L2 turns on to signal High point cal.
			
9) Set signal generator to High signal (e.g., 20mA). Wait 2 seconds.	10) Press HIGH button 1 time to save High point.	11) All 3 LED's turn on (BLUE) to indicate that the values are saved.	12) The L3 LED turns on (BLUE = MANUAL Mode). Normal operation.
<p>TIPS</p> <p>BY-PASS A POINT -- To by-pass a point press the MODE button instead of LOW or HIGH buttons.</p> <p>REVERSE ACTING – Apply a high signal (20mA) to the low point. Apply a low signal (4mA) to the High point.</p> <p>SPLIT RANGE – Apply a mid-signal (12mA) to the low point. Apply a high signal (20mA) to the high point.</p> <p>LOSS of SIGNAL – On signal < min cal. value, XAE will adjust to 0% setting.</p> <p>OVER SIGNAL – On signal > max cal. value, XAE will adjust to 100% setting.</p>			

ANALOG OUTPUT CALIBRATION

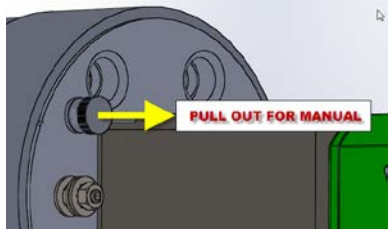
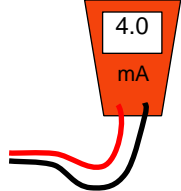
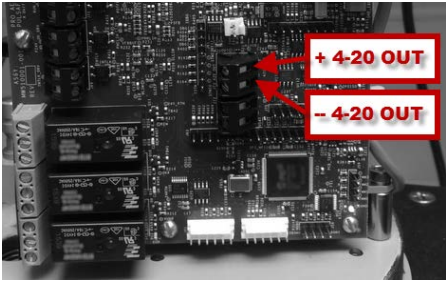
SET MANUAL MODE	EQUIPMENT	CONNECTION
	 <p style="text-align: center;">Meter set to mA Current Range</p>	

CALIBRATE - ANALOG OUTPUT (4-20mA)

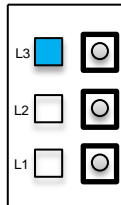
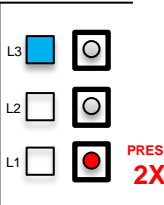
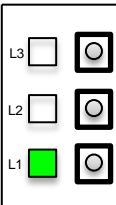
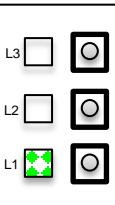
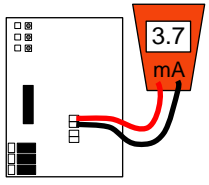
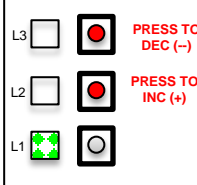
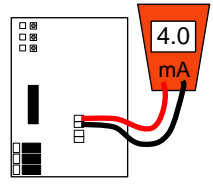
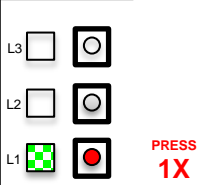
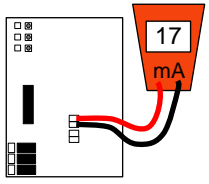
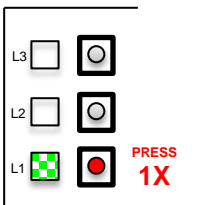
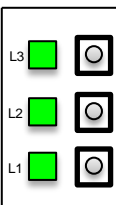
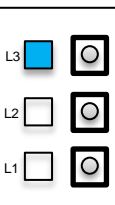
			
1) Power On, set MANUAL, wait for L3 to turn on (BLUE).	2) Press and release MODE 2 times to select 4-20 output calibration.	3) LED L1 turns on BLUE then GREEN. Wait for L1 flash.	4) LED L1 flashes slow to signal Low point calibration.
			
5) Attach meter to J17-1 (-) and J17-2 (+). Reads low value.	6) Press Increase (+) to increase setting, Decrease (-) to reduce.	7) Repeat #6 until meter reads correct low value (4mA).	8) Press and release MODE to save low point. L1 LED flashes fast.
			
9) Read High value from the meter. Repeat step #6 to adjust output value.	10) Press and release the MODE button 1 time to save the High point value.	11) All 3 LED's turn on (GREEN) to indicate that the values are saved.	12) The L3 LED turns on (BLUE = MANUAL Mode). Normal operation resumes.

TIPS

BY-PASS A POINT - To by-pass a point press the MODE without pressing the LOW or HIGH buttons.

REVERSE ACTING - Set a high signal value (20mA) for the low point. Set a low value (4mA) for the High point.

SPLIT RANGE - Set a mid-level signal value (12mA) to the low point. Set a high value (20mA) to the high point.

MECHANICAL (0%/100%) CALIBRATION

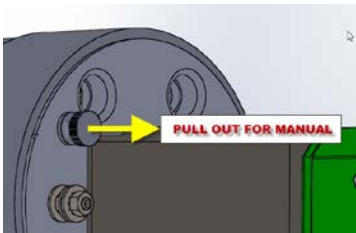
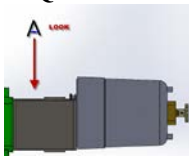
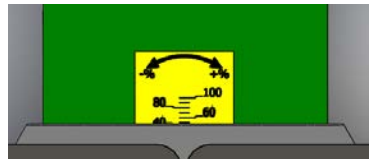
<p>SET MANUAL MODE</p> 	<p>EQUIPMENT</p>  <p>Read Setting</p>	<p>IDENTIFY</p>  <p>Setting</p>
---	--	--

CALIBRATE – MECHANICAL (0%/100%)

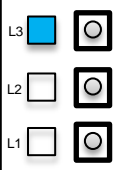
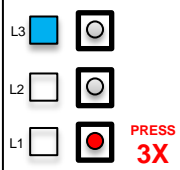
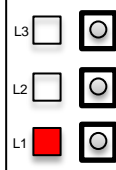
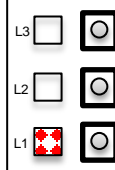
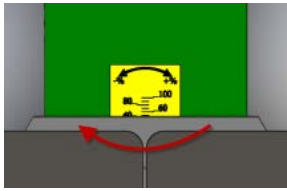
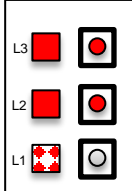
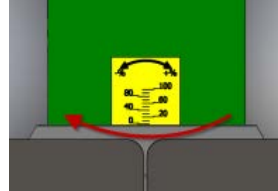
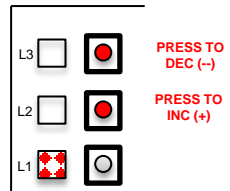
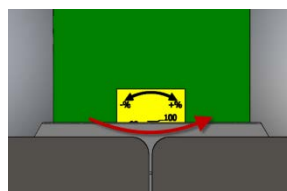
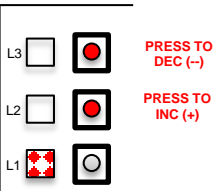
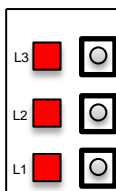
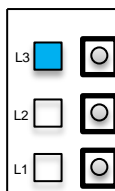
			
<p>1) Power On, set MANUAL, wait for L3 to turn on (BLUE).</p>	<p>2) Press and release MODE 3 times to select mechanical cal.</p>	<p>3) LED L1 turns on RED. Wait for L1 flash.</p>	<p>4) LED L1 flashes slow to signal mechanical calibration.</p>
			
<p>5) The Actuator will adjust the knob to its reference point – around 50%.</p>	<p>6) Wait for the L2 and L3 LED's to both turn RED and the knob to stop. Press MODE.</p>	<p>7) The knob will turn to around 10% and stop. The L2 and L3 LED's will turn off.</p>	<p>8) Press INC(+) or DEC(-) to set the knob position to 0%. Once it stops, press MODE to save.</p>
			
<p>9) Wait for the knob to turn to around 90% and stop. The L2 and L3 LED's will turn off.</p>	<p>10) Press INC(+) or DEC(-) to set the knob position to 100%. Once it stops, press MODE to save.</p>	<p>11) All 3 LED's turn on (RED) to indicate that the values are saved.</p>	<p>12) The L3 LED turns on (BLUE = MANUAL Mode). Normal operation resumes.</p>

TIPS

BY-PASS A POINT - To by-pass a point press the MODE without pressing the LOW or HIGH buttons.

SCALE RANGE – To scale the operating range of the actuator, set the 100% point to a lower value (75% for example). This will scale the input and the output so 4mA = 0% and 20mA = 75%.



Pulsafeeder, Inc.
2883 Brighton Henrietta Town Line Road
Rochester NY 14623
+1 (585) 292-8000
www.pulsa.com