

# PulsaPro® 7120

## HYDRAULIC DIAPHRAGM METERING PUMP

PulsaPro® 7120 is a positive displacement, leak-free, hydraulically balanced diaphragm metering pump, engineered for precise dosing and long-term dependability, delivering superior value. It offers a diverse range of fluid handling solutions with unique pump head designs consisting of HYDRAtube® or flat diaphragm types, each available in a variety of wet-end materials. PP7120 features immediate visual intelligence about pump and system performance. It complies with the API 675 standard for use in oil & gas, petrochemical, chemical processing, power generation, and water & wastewater treatment industries.



### Applications

- corrosion inhibitors
- anti-scalants
- slurries
- Sodium Hypochlorite
- disinfection
- pH and odor control



### Flow

up to 248 gph (939 lph)



### Pressure

up to 3,100 psi (213.7 bar)



### Temperature

up to 250°F (121°C)



API 675, CE, ATEX



### Standard materials of construction

- Wet end: 316LSS, GF-PTFE, PVC
- Diaphragm: PTFE
- Valve ball: 316LSS, Alumina Ceramic
- Valve seat: 316LSS, PVC, GF-PTFE
- Valve gaskets: PTFE
- Pump body: Cast Iron

### Connection types

- NPT
- Raised-face flange

### Controls

- Manual stroke length control
- Electronic stroke length control

### Leak detection

- PULSAlarm®
  - Pressure based
  - IP66, NEMA Type 4X, NEMA TYPE 7

### Multiplex configurations

- up to 17 pumps

### HYDRAtube design

- The solution for shear sensitive and high viscosity fluids
- Straight flow-through path
- Double diaphragm safety
- Optional slurry valves
- Robust Ductile Iron housing
- Elastomeric HYDRAtube
- ChemAlarm® leak detection

## DIMENSIONS

Approximate shipping weight: 110 lb. (50 kg.)

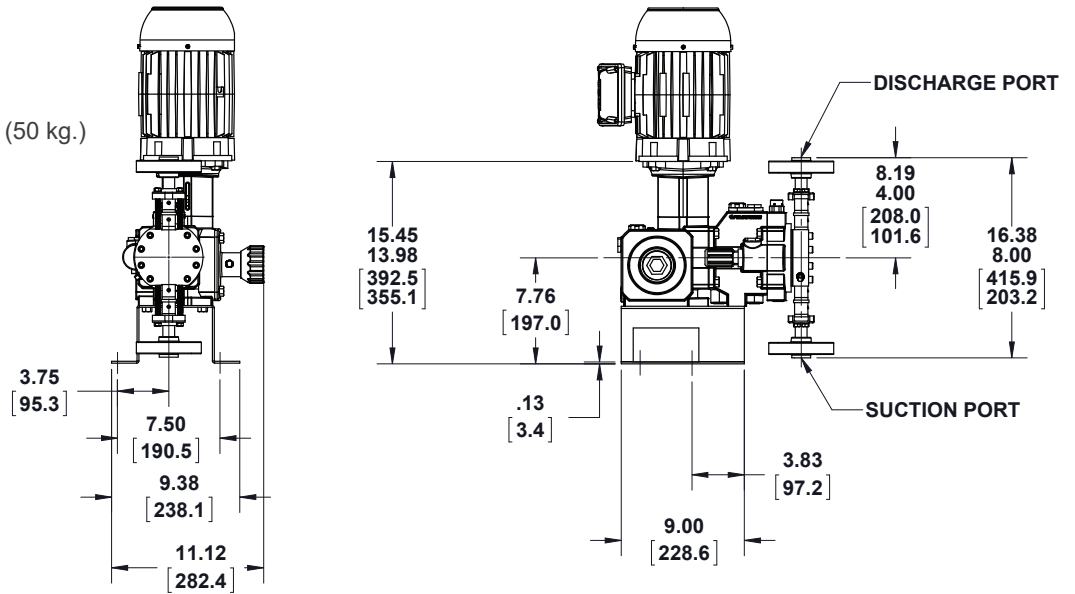

Inches  
[Millimeters]

The dimensions given may differ depending on pump configuration.

## FEATURES & BENEFITS

- Unique 3 valve hydraulic management system makes the PulsaPro pump resilient to system upset
- **Hydraulic performance valve** maintains optimum diaphragm position and allows low suction NPIP of 5 psi (0.345 bar)
- **Push-to-prime valve** allows quick manual priming of the hydraulic system in addition to automatic air bleeding
- Externally adjustable **hydraulic by-pass valve** protects against over-pressurization
- Four bolt tie bar design provides ultimate resistance to piping moments and forces
- Three component check valves for controlled fluid displacement, assuring reliable hydraulic operation
- Manual stroke length adjustment with resolution of 0.5% for set point accuracy and optional electronic stroke length adjustment with 5x improved resolution

## CUSTOM ENGINEERING

- Compatible materials: Alloy C, Alloy 20, Monel®, DuplexSS, Titanium, PVDF
- Minimum temperature to -10°F (-23°C)
- Degass Valve
- Chemical feed systems
- Application consulting

## SPECIFICATIONS

<b>Materials</b>	316LSS, PVC, GF-PFTE	<b>Max temp</b>	250°F (121°C)
<b>Diaphragm type</b>	Flat, Tube	<b>Min temp</b>	40°F (4.4°C)
<b>Motor power</b>	up to 1.5 hp (1.1 kW)	<b>Accuracy</b>	±0.5%
<b>Motor frame</b>	NEMA 56C, 143/5TC, 182/4TC IEC 71B14, 80B14, 90B14	<b>Standards</b>	API 675, CE, ATEX

## FLOW & PRESSURE ENVELOPE

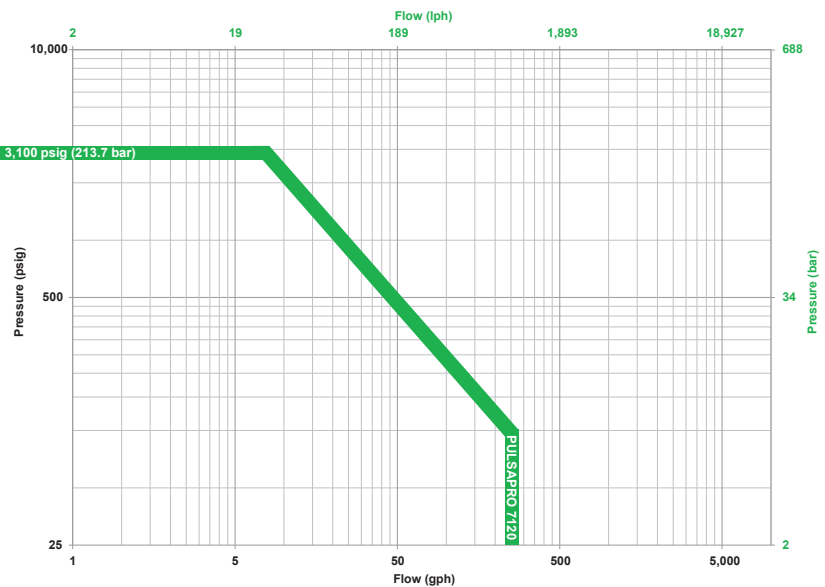

**Pulsafeeder, Inc.**  
 2883 Brighton Henrietta Town Line Rd.  
 Rochester, NY 14623  
 Phone: +1 (585) 292-8000  
 pulsa@idexcorp.com • [pulsa.com](http://pulsa.com)

*Pulsafeeder is an ISO 9001 Certified Company.*

pulsa7120spec\_Rev0720