

PulsaPro® 880

HYDRAULIC DIAPHRAGM METERING PUMP

PulsaPro® 880 is a positive displacement, leak-free, hydraulically balanced diaphragm metering pump, engineered for precise dosing and long-term dependability, delivering superior value. It offers a diverse range of fluid handling solutions with unique pump head designs consisting of HYDRAtube® or flat diaphragm types, each available in a variety of wet-end materials. PP880 features immediate visual intelligence about pump and system performance. It complies with the API 675 standard for use in oil & gas, petrochemical, chemical processing, power generation, and water & wastewater treatment industries.



Applications

- corrosion inhibitors
- anti-scalants
- slurries
- Sodium Hypochlorite
- disinfection
- pH and odor control



Flow

up to 115 gph (435.3 lph)



Pressure

up to 3,100 psi (213.7 bar)



Temperature

up to 250°F (121°C)



API 675, CE, ATEX



Standard materials of construction

- Wet end: 316LSS, GF-PTFE, PVC
- Diaphragm: PTFE
- Valve ball: 316LSS, Alumina Ceramic
- Valve seat: 316LSS, PVC, GF-PTFE
- Valve gaskets: PTFE
- Pump body: Cast Iron

Connection types

- NPT
- Raised-face flange

Controls

- Manual stroke length control
- Electronic stroke length control

Leak detection

- PULSAAlarm®
 - Pressure based
 - IP66, NEMA Type 4X, NEMA TYPE 7

Multiplex configurations

- up to 17 pumps

HYDRAtube design

- The solution for shear sensitive and high viscosity fluids
- Straight flow-through path
- Double diaphragm safety
- Optional slurry valves
- Robust Ductile Iron housing
- Elastomeric HYDRAtube
- ChemAlarm® leak detection

DIMENSIONS

Approximate shipping weight: 95 lb. (43 kg.)

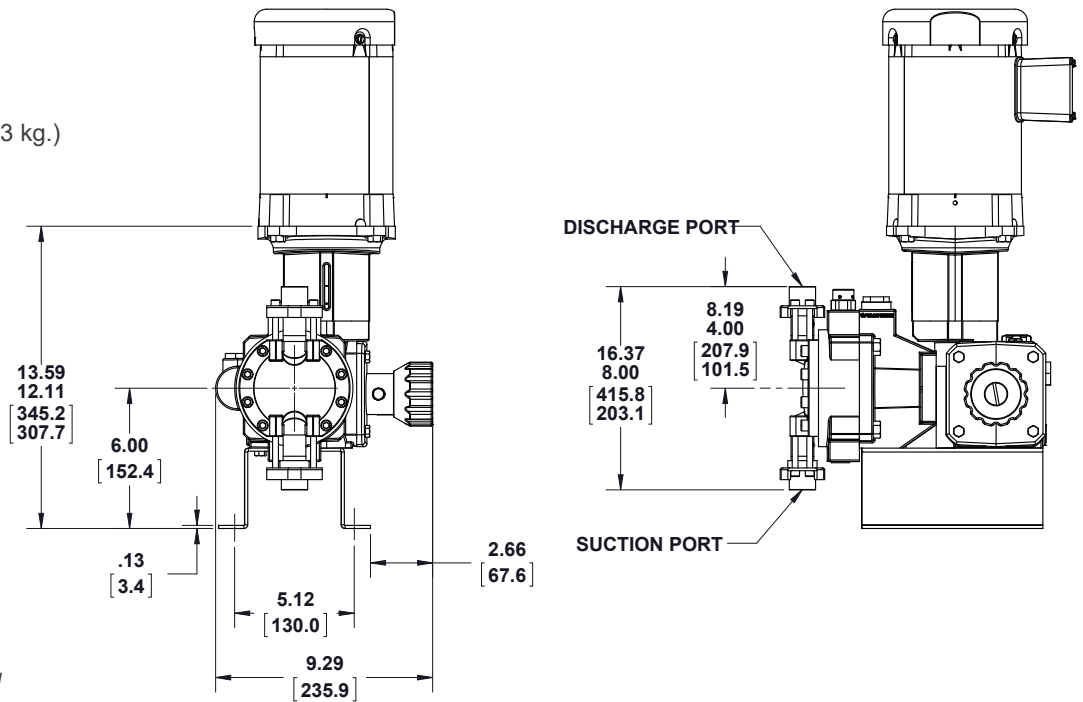

Inches
[Millimeters]

The dimensions given may differ depending on pump configuration.

FEATURES & BENEFITS

- Unique 3 valve hydraulic management system makes the PulsaPro pump resilient to system upset
- **Hydraulic performance valve** maintains optimum diaphragm position and allows low NPIP of 5 psi (0.345 bar)
- **Push-to-prime valve** allows quick manual priming of the hydraulic system in addition to automatic air bleeding
- Externally adjustable **hydraulic by-pass valve** protects against over-pressurization
- Four bolt tie bar design provides ultimate resistance to piping moments and forces
- Three component check valves for controlled fluid displacement, assuring reliable hydraulic operation
- Manual stroke length adjustment with resolution of 0.5% for set point accuracy and optional electronic stroke length adjustment with 5x improved resolution

CUSTOM ENGINEERING

- Compatible materials: Alloy C, Alloy 20, Monel®, DuplexSS, Titanium, PVDF
- Minimum temperature to -10°F (-23°C)
- Degass Valve
- Chemical feed systems
- Application consulting

SPECIFICATIONS

Materials	316LSS, PVC, GF-PTFE	Max temp	250°F (121°C)
Diaphragm type	Flat, Tube	Min temp	40°F (4.4°C)
Motor power	up to 0.5 hp (0.37 kW)	Accuracy	±0.5%
Motor frame	NEMA 56C, 143/5TC IEC 71B14, 80B14, 90B14	Standards	API 675, CE, ATEX

FLOW & PRESSURE ENVELOPE

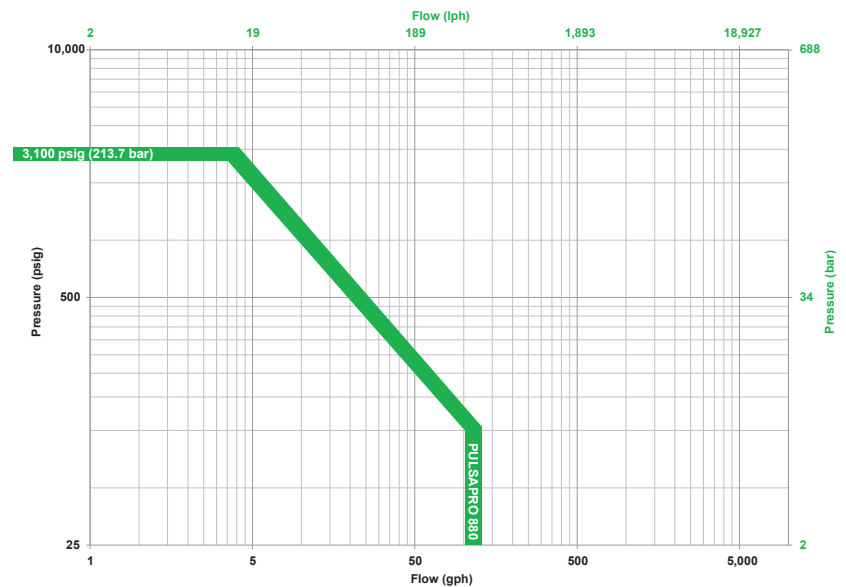

Pulsafeeder, Inc.
2883 Brighton Henrietta Town Line Rd.
Rochester, NY 14623
Phone: +1 (585) 292-8000
pulsa@idexcorp.com • pulsa.com

Pulsafeeder is an ISO 9001 Certified Company.

pulsa880spec_Rev0720