

PULSAR® 55H

HYDRAULIC DIAPHRAGM METERING PUMP

PULSAR 55H is a leak-free, hydraulically balanced diaphragm metering pump, engineered for precise dosing and long-term dependability to deliver superior value. It includes exclusive hydraulic diagnostics that provide immediate visual intelligence about pump and system performance. The PULSAR HYPOPump® configuration is the ideal choice for Sodium Hypochlorite or other off-gassing and difficult to handle fluids. PULSAR 55H is commonly used for applications in industries such as chemical processing, petrochemical, oil & gas, water & wastewater treatment, and power.



API 675, CE, ATEX



Applications

- corrosion inhibitors
- anti-scalants
- slurries
- Sodium Hypochlorite
- disinfection
- pH and odor control



Flow

up to 120 gph (453 lph)



Pressure

up to 4,000 psi (276 bar)



Temperature

up to 230°F (110°C)



Standard materials of construction

- Wet end: 316LSS, PVC
- Diaphragm: Composite or Solid PTFE
- Pump body: Aluminum
- Valve ball: 316LSS, Alumina Ceramic
- Valve gaskets: PTFE
- Valve seat: 316LSS, PVC

Connection types

- NPT
- Raised-face Flange

Controls

- DLC - stroke length
- DLCM - stroke length/motor speed
- MPC - motor speed
- ECA - stroke length

Leak detection

- PULSAlarm®
- Pressure based
- IP66 NEMA Type 7/4X

Duplex configurations

PULSAR HYPOPump

- The solution for injection of sodium hypochlorite and other off gassing fluids
- Fully integrated closed loop design, no external valves or piping required
- Balanced, low stress, dynamic seal ensures extended operating life
- 3 year HYPO valve warranty

PULSAFEEDER®
ENGINEERED PRODUCTS

FLOW & PRESSURE ENVELOPE BY PISTON SIZE (mm)

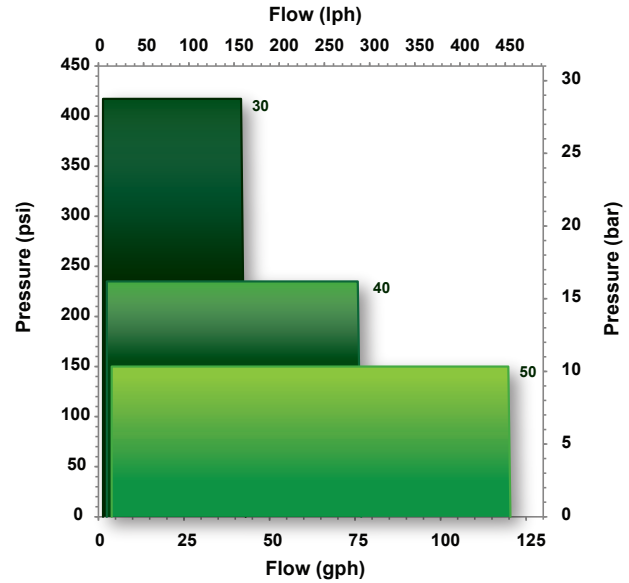
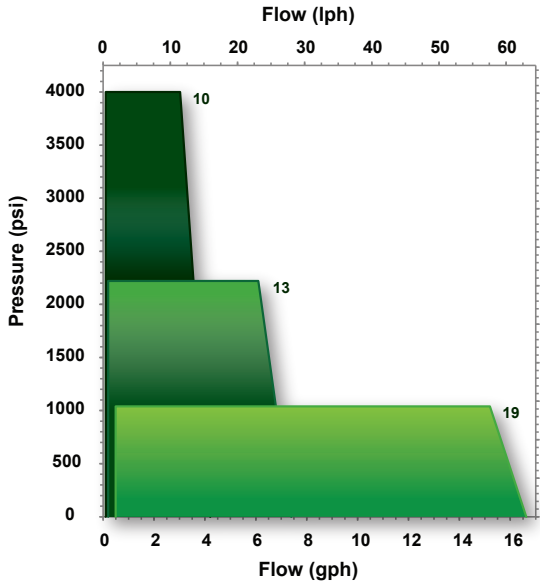

FEATURES & BENEFITS

- Patented hydraulic diagnostic window yields instant visual indication of system over-pressurization, entrained air in hydraulic fluid and diaphragm integrity
- Hydraulic Performance Valve maintains optimum diaphragm position and allows low suction NPIP of 3 psi (0.2 bar)
- Push-to-prime valve allows quick manual priming of the hydraulic system in addition to automatic air bleeding
- Four bolt tie bar design provides ultimate resistance to piping moments and forces
- Three component check valves for controlled rise, assuring proper valve operation, extended valve seat life, and metering accuracy
- Externally adjustable hydraulic by-pass valve protects against over-pressurization
- Manual self-locking stroke length adjustment with resolution of 0.5% for set point accuracy

SPECIFICATIONS

Materials	316LSS, PVC	Max temp	230°F (110°C)
Diaphragm type	Flat	Min temp	40°F (4.4°C)
Motor power	0.75 hp (0.55 kW)	Accuracy	±0.5%
Motor frame	NEMA 56C, IEC 80B14	Standards	API-675, CE, ATEX

DIMENSIONS

Approximate shipping weight: 110 lb. (50 kg.)

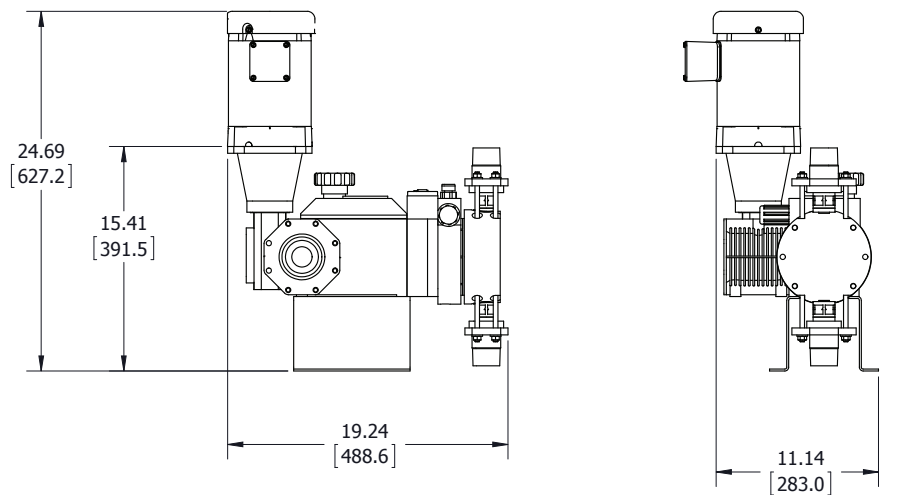

The dimensions given may differ depending on pump configuration.

Pulsafeeder, Inc.

2883 Brighton Henrietta Town Line Rd.
Rochester, NY 14623
Phone: +1 (585) 292-8000
pulsa@idexcorp.com • pulsa.com

Pulsafeeder is an ISO 9001 Certified Company.

CUSTOM ENGINEERING

- Compatible materials: Alloy C, Alloy 20, Monel®, DuplexSS, Titanium, PVDF
- Minimum temperature to -10°F (-23°C)
- Multiplex configurations
- Manual Degass Valve
- Custom electronic controls
- Chemical feed systems
- Application consulting