

Pulsafeeder innovation produced the DLC, the first available on-board flow calibration controller. The DLC Stroke Length Controller is simple to use and provides the ability to remotely control the stroke length of Pulsar metering pumps. It displays information in worldwide units and four languages to over on-board system diagnostics at a glance.

Key Features

- 10:1 Turndown capability with a +/-1% steady state on set point accuracy
- Ability to perform programmed batching operations, timed interval and cycle injections
- On-board system diagnostics measure flow calibration, analog input calculation and output calculation
- Back-lit, 2 line, 16 character LCD display
- Operator can choose to perform a single point or multi-point flow calibration
- Maximum and minimum values are digitally stored
- Fully compatible on any worldwide power supply
- Select either English or Metric units of flow
- Can display in four languages: English, French, Spanish and German
- Analog input and output signals of 0-20mA, 4-20 mA, 1-5 mA, or 1-5 VDC
- Displays in percentage of stroke, gph, lph, cc/hr, gpm, lpm and cc/min
- Directly interfaces with PULSAlarm Leak Detection which will stop the motor, trigger an alarm or both
- High-visibility local pump stop/start button
- 10 year full battery back-up of all settings
- Internal diagnostics archives functions and errors to aid in troubleshooting and maintenance
- Password protection of calibration or all settings
- Exclusive manual override capability
- MODBUS communications capable
- Remote start/stop feature
- Remote status feature
- Alarm status output
- Standard enclosure meets NEMA 4X, EEMAC 4X and IP66. NEMA7 enclosure option available.

Operating Benefits

- Easily retrofits manual pumps to DLC stroke length controller
- Unique connector board requires electrical connections to be installed only once
- Mechanical override allows continued flow control in the event of a signal loss
- Automatically adjusts to your analog input and output signals-no internal adjustments required



Other Accessory Offerings

- KOPkits[®]
- Calibration Columns
- Y Strainers
- Pressure Relief Valves
- Back Pressure Valves
- Pulsation Dampeners
- Pressure Gauges
- PULSAlarm Leak Detection



PULSAR[®] **DLC**

DIGITAL STROKE LENGTH CONTROLLER

Keyboard Display

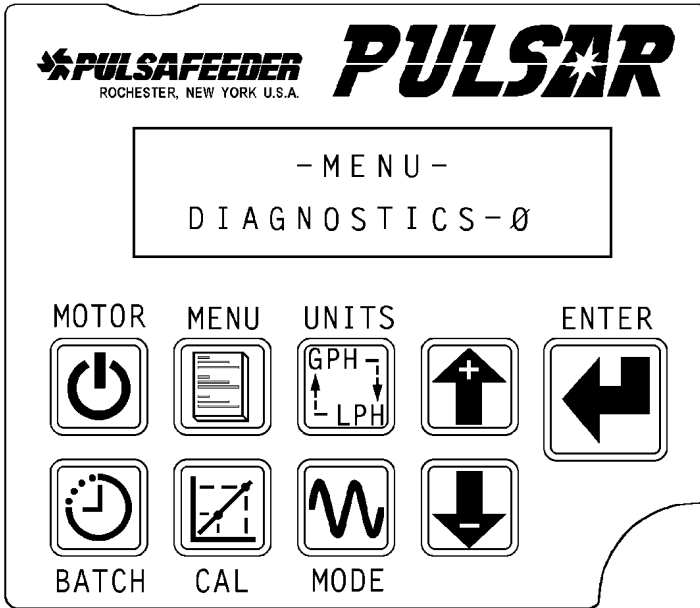

Keyboard Displays	
Percentage of Stroke	100%
Gallons Per Hour (GPH)	100 GPH
Liters Per Hour (LPH)	378.5 LPH
Cubic Centimeters Per Hour (cc/hr)	378,540 cc/Hr
Gallons Per Minute (GPM)	1.67 GPM
Liters Per Minute (LPM)	6.31 LPM
Cubic Centimeters Per Minute (cc/Min)	6309 cc/Min

Engineering Data

- Power Input Options:** Single Phase, 115 or 230VAC (50 or 60 Hz)
- Analog Input/output:** One of each, Range is 4-20 mA
- Stroke Length Control:** 0-100% control range
0.1% resolution
10:1 turndown for accuracy specification
- Combined Calibrated Flow:** 6 significant digits for displayed units of flow
- Adjustment Response:** 1% per second on stroke length
1% per second on steady state speed
- Ambient Rated Temperature:** 0°-104°F (18°C-40°C)
- Steady State Accuracy:** +/- .5% over a 10:1 speed turndown

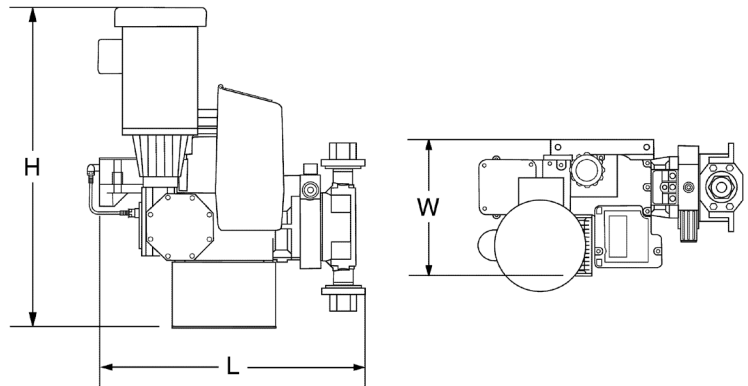

Dimensions

DIM	Inches & Millimeters	
	Inch	MM
L	23	575
W	11	270
H	29	736
Approx Shipping Weight	80-100 lbs	36-45 Kg.