

MicroVision^{EX}

MICROPROCESSOR – BASED
WATER TREATMENT
CONTROLLER

Installation Operation Manual

Table of Contents

1.	GENERAL WARNINGS	4
2.	<i>MicroVision</i> ^{EX} FEATURES	4
3.	INSTALLATION	6
3.1	Location.....	6
3.2	Mounting Hardware.....	6
3.3	Opening the Enclosure.....	6
3.4	Sensor Installation.....	7
3.5	TYPICAL INSTALLATION	7
3.6	IMPORTANT SYMBOL INFORMATION.....	8
3.7	ELECTRICAL WIRING	8
3.8	Flow Switch Input	12
3.9	Sensor (probe) Connection Input.....	12
3.10	Water Meter Input	12
3.11	Drum Level Input.....	12
3.12	4-20mA Output.....	12
3.13	4-20mA Input	12
3.13.1	Fluorometer – Trace Chemical.....	13
3.13.2	Calibrating PTSA Probe	14
3.14	Alarm Dry Contact Relay	14
3.15	Keypad Operation	15
3.16	Communications (Optional)	15
4.	CONTROLLER PROGRAMMING.....	16
4.1	Menu Map.....	16
4.2	Menu Navigation.....	16
4.3	Home screen.....	16
4.4	Main Menu.....	17
4.5	Relay HOA.....	17
4.6	Configure.....	17
4.6.1	Date/Time	17
4.6.2	Digital Inputs	18
4.6.3	4-20mA Out and 4-20mA In.....	18
4.6.4	Gal/Lit.....	18
4.6.5	Meter Totals.....	18
4.6.6	Languages Menu.....	18
4.6.7	Display Settings.....	19
4.6.8	Password Setting.....	19
4.6.9	Software Version	20
4.6.10	Factory Reset Function.....	20
4.7	Settings.....	20
4.7.1	Conductivity	20
4.7.2	pH and ORP	22
4.7.3	4-20mA Outputs (Optional Accessory)	24
4.7.4	4-20mA Inputs (Optional Accessory)	24
4.8	Timers - Modes	24
4.8.1	Timers – Pulse Timer	25
4.8.2	Timers – Percent Timer	25
4.8.3	Timers - 28 day (Biocide Timer)	25
4.8.4	Timers – % Post Bleed.....	26
4.8.5	Timers – Limit Timer (Bleed and Feed).....	26
4.8.6	Timers – Alarm.....	26

4.8.7	Timers – Set Point Control Mode	26
4.8.8	Timers – Disabled (Default)	27
4.8.9	Timers – Bio Tracking (In All Timer Modes)	27
4.9	Communications	27
4.10	USB	27
4.10.1	USB Graphing Tool	28
4.10.2	USB Data log Timer and Tamper Codes:	28
4.11	Ethernet (Optional)	29
4.11.1	Programming your controller PulsaLink	29
4.11.2	Setting Up Your Controller on PulsaLink	29
5.	FACTORY DEFAULTS	30
6.	TROUBLESHOOTING GUIDE	32
7.	MAINTENANCE	33
7.1	Conductivity Sensor removal and cleaning	33
	To remove the conductivity sensor from its tee for cleaning:	33
	To clean conductivity sensor:	33
7.2	pH sensor Information	33
7.2.1	Preparation	33
7.2.2	Sensor Storage	34
7.2.3	Sensor Cleaning	34
7.3	ORP Sensor Information	34
7.3.1	ORP Maintenance and Troubleshooting	34
7.3.2	Testing ORP Sensor	34
7.3.3	Flow Sensor	35
8.	SPECIFICATIONS	35
9.	FORSEABLE MISUSE	36
10.	MOUNTING HOLE PATTERN (Footprint)	37

Introduction

The *MicroVision^{EX}* microprocessor based cooling tower controller has been designed to monitor and control Total Dissolved Solids (TDS) in terms of electrical conductivity measured in micro Siemens per centimeter (uS/cm). Some models also include pH, and ORP control. A set point of the desired value to control is entered into the controller through the front panel. As this limit is exceeded, a valve, pump or other control device is activated via an onboard control relay to adjust the reading being measured.

1. GENERAL WARNINGS

- ⚠ Symbol hereinafter and upon the unit means WARNING!
- ⚠ If the equipment is used in a manner not specified by the manufacture, the overall safety may be impaired.
- ⚠ The plug is considered mains power. Disconnection means should be readily identifiable and easily accessible to the operator after install
- ⚠ Adequately rated and APPROVED/CERTIFIED power supply cord and plug (supplied by Pulsafeeder), or cable gland suitable for the applicable country is to be attached and replaced by manufacturer's authorized qualified person or as per applicable local and national regulations
- ⚠ Controller is for indoor use only and not suitable for wet location. Controller housing is IP65 compliant and may be configured as such.
- ⚠ Verify the mains supply ratings (e.g. Volts, Amps, and Hz) where the controller is to be powered from and ratings of the accessories as well as ratings of the controller's receptacles/outlets before powering up.

2. *MicroVision^{EX}* FEATURES

Toroidal Probe

MicroVision^{EX} uses a toroidal probe for conductivity measurement. The measurement is made by passing an AC current through a toroidal drive coil, which induces a current in the electrolyte solution. This induced current in turn, induces a current in a second toroidal coil, called the pick-up toroid. The amount of current induced in the pick-up toroid is proportional to the solution conductivity.

Output Relays

The control of the HANDS – OFF – AUTO (HOA) output relays can be controlled using the HOA menu.

RELAY STATUS	LED COLOR
ON (FORCED ON FOR 5 MIN.)	AMBER
OFF	RED
AUTOMATIC 'ON'	GREEN
AUTOMATIC 'OFF'	OFF

Drum Levels

Three (3) onboard dry contact inputs serve as Drum Level inputs. When a low level is detected the unit will go into an alarm state and the low drum's identity will be displayed on the screen. The user can program the alarm to deactivate a timer if desired. Drum level #1 is assigned to timer #1, drum level #2 is assigned to timer #2 and drum level #3 is assigned to timer #3.

Flow Switch

MicroVision^{EX} has a dry contact flow switch input that will de-activate all of the control output relays upon a no-flow indication. An alarm condition will be indicated and "Flow Switch Alarm" will be displayed. This input is active closed:

Open = no flow; closed = flow.



If a flow switch input or other alarm condition exists, the LED's on the front panel will flash until the alarm condition is cleared.

4-20mA Outputs and Inputs

Optional 4-20mA inputs or outputs can be installed to increase the capabilities of the *MicroVision^{EX}*. Connect 4-20mA equipment to the + and - terminals as shown on page 9.

Water Meter

MicroVision^{EX} has a dedicated water meter input that is capable of reading a dry contact or Hall effect type water meter. Through programming this input can be used to signal a pulse timer as well as totalizing water consumption. Some models offer up to six (6) water meter inputs.

Alarm Relay

MicroVision^{EX} has a dedicated dry contact relay that can be used to interface with process control equipment or visual indicators. This relay is un-powered.

3. INSTALLATION

3.1 Location

Select a mounting location convenient to grounded (True Earth) electrical and plumbing connections. It is recommended that the controller is mounted on a wall or other vertical surface with adequate lighting at a comfortable level. Installation should comply with all national, state, and local codes.



Avoid locations where the controller would be subjected to direct sunlight, extreme cold, heat, or humidity {less than 36°F (2.2°C) or greater than 122°F (50°C), or greater than 95% RH non-condensing, direct sunlight, vibration, vapors, liquid spills, or EMI (electromagnetic interference; e.g., strong radio transmission and electric motors.) Install at less than 2000m above sea level.



SAFETY PROTECTION PROVIDED BY THE EQUIPMENT MAY BE IMPAIRED IF THE EQUIPMENT IS USED IN A MANNER NOT SPECIFIED BY THE MANUFACTURER. THIS CONTROLLER IS INTENDED FOR INDOOR USE ONLY AND NOT SUITABLE FOR WET LOCATION.

3.2 Mounting Hardware

Mount the controller using the four (4) holes provided.

Typically, use a #8 screw or equivalent. The mounting screw should be appropriate for the location mounting on, i.e., sheet metal screws for mounting onto sheet metal, wood screws for mounting onto wood or wall studs, and hollow wall drywall anchors for mounting to drywall. Mount should be designed for 7.5 Kg, 17 lbs.

- ⚠ Mount the unit ergonomically, such that the unit is visible without excessive bending or lowering of the body, and not too high such that the internals are not visible with opening the enclosure.

3.3 Opening the Enclosure

Loosen the knob that secures the clear front cover. Then loosen four (4) screws in the four corners of the front of the controller and carefully swing the top of the case forward.



3.4 Sensor Installation

Conductivity

The controller is supplied with a temperature compensated toroidal conductivity probe installed in a tee. The probe should only be installed where adequate flow is going around and through the hole in the center of the probe in the tee provided.

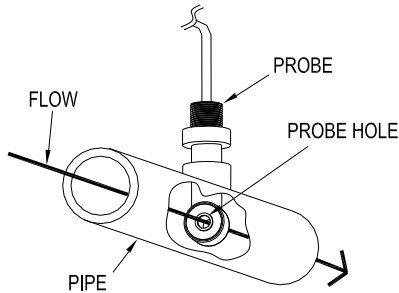

pH and ORP

When ordered as a pH or ORP model the controller will be supplied with standard pH and ORP probes. The probes are supplied installed in a tee. The probes should only be installed where flow between 1 and 5 GPM is going around the probe.

Flow Switch

If the controller is provided with a flow switch, install the flow switch so that flow enters into the bottom of the flow switch tee, and out the side of the tee. The flow switch must always be installed in a vertical position so that the sensor wire is coming out of the top, and the internal (red) flow shuttle is able to rise when there is flow and drop when there is no flow. The flow switch is activated when 1 GPM (3,8 LPM) is going through it, and is deactivated when the flow drops below 1 GPM (3,8 LPM).

3.5 TYPICAL INSTALLATION

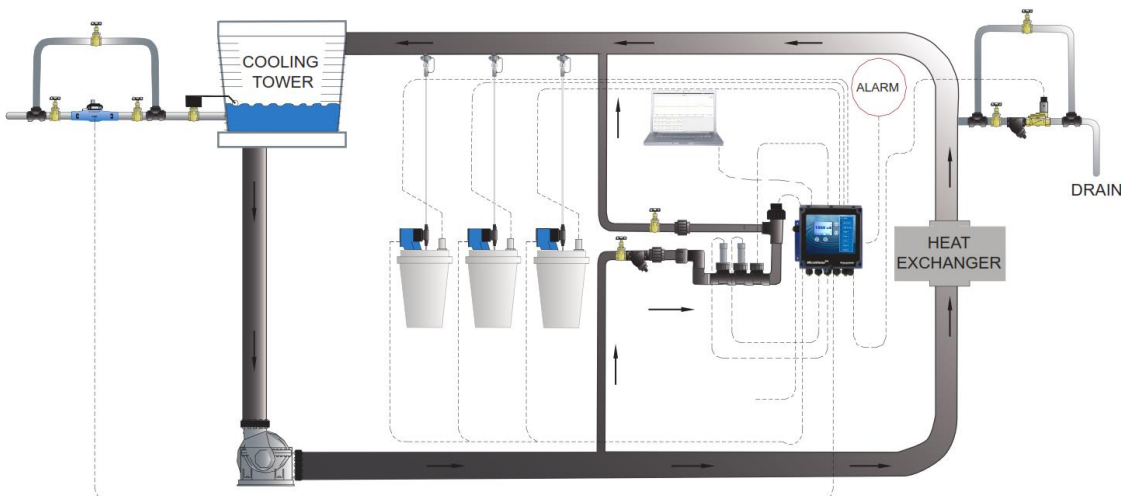

⚠ Over pressurization of the plumbing can occur when cooling tower is higher than the piping and controller system. Ensure all pressures have been accounted for. Verify piping and sensor allowable temperatures are above maximum temperatures of the system.

3.6 IMPORTANT SYMBOL INFORMATION



Warning indicates a condition that could cause damage to both the equipment and the personnel operating it. Pay close attention to any warning.



Primary Supply Ground must be connected to earth ground for safe operation of the controller.



Chassis Ground – Connect the equipment’s ground wire here for safe operation of external devices.



Notes to provide tips and hints

3.7 ELECTRICAL WIRING



CONTROLLER MUST BE WIRED IN ACCORDANCE WITH ALL APPLICABLE ELECTRICAL CODES, NEC, CSA, EN, OR LOCAL AUTHORITY HAVING JURISDICTION.

The *MicroVision^{EX}* electronic input circuitry is fuse protected on both the hot and neutral inputs using a replaceable eight amp fuse (see page 9). For additional protection of this instrument, use of a surge protector is recommended.



The controller should be connected to a dedicated power branch (i.e., its own wiring, GFCI circuit breaker, etc.). For best results, the ground should be independent (true earth) not shared.



A switch or circuit-breaker, marked as the unit’s disconnecting device should be included in the installation. It should be in close proximity to the unit and be easily reached by the operator.

Pre-wired controllers are supplied with a 3-wire grounded power cord and 3-wire grounded receptacle cords for all controlled line voltage outputs.

- ⚠ Plug is considered as mains power disconnecting device which shall be readily identifiable and easily accessible.

RELAY BOARD CONNECTIONS

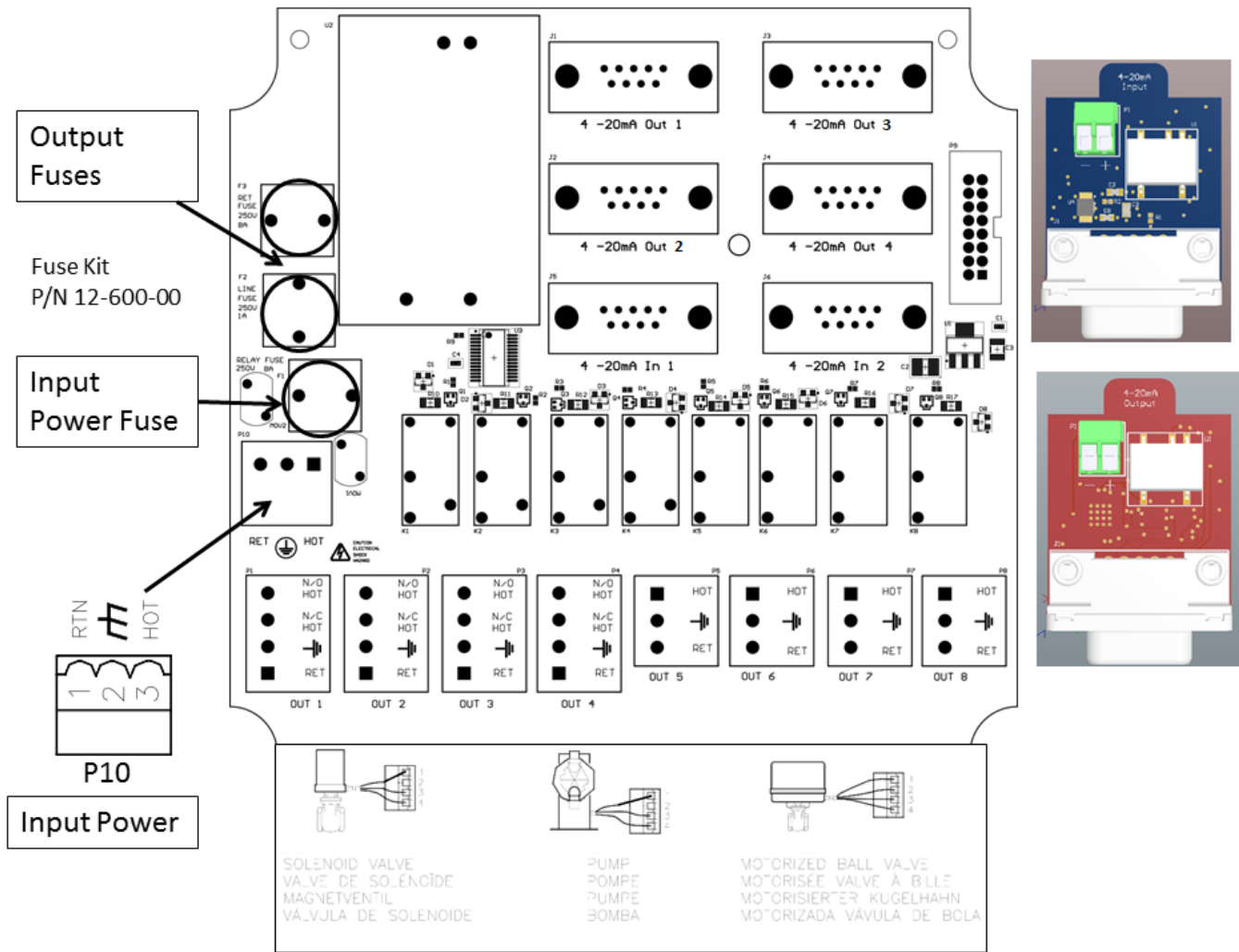

Energy Usage and Duty

The unit utilizes a variety of probes and input signals to control valves, pumps, and numerous other devices. These items are not all used in a continuous fashion. The typical unit has a complicated duty cycle dependent on application. For 120V and a max of 8A, a typical duty cycle of 15 minutes on and 45 minutes off can be used. This results in an energy calculation of

$$120V * 8A * \text{Power Factor} * 25\%$$

The Power Factor is the cosine of the phase angle between the Current and Voltage of an AC circuit. Typically, 0.8 is a good estimate for US power.

The 25% is the estimate of a typical duty cycle of 15 on and 45 off.

For 240V, the amperage remains constant.

Relay Assignments

	Relay 1	Relay 2	Relay 3	Relay 4	Relay 5	Relay 6	Relay 7	Relay 8	Dry contact
Model	OUT 1	OUT 2	OUT 3	OUT 4	OUT 5	OUT 6	OUT 7	OUT 8	P4
MVECXXX	Bleed	Timer 1	Timer 2	Timer 3					Alarm
MVEC5XX	Bleed	Timer 1	Timer 2	Timer 3	Timer 4				Alarm
MVECPXX	Bleed	pH	Timer 1	Timer 2	Timer 3	Timer 4	Timer 5	Timer 6	Alarm
MVECOXX	Bleed	ORP	Timer 1	Timer 2	Timer 3	Timer 4	Timer 5	Timer 6	Alarm
MVECPOX	Bleed	pH	ORP	Timer 1	Timer 2	Timer 3	Timer 4	Timer 5	Alarm
MVECPOM	Bleed	pH	ORP	Timer 1	Timer 2	Timer 3	Timer 4	Timer 5	Alarm

Conduit Models (Wiring High Voltage)

Conduit controllers have openings for conduit connections for hard wiring. Use only 18 AWG (1,2 mm²) stranded wire for conduit power and load connections. Supply (input) power is connected via **P10** located on the relay board. The top part of this terminal block is removable to allow for easy access to the connector's three (3) screws. For CE rated models ensure all ferrites are installed in their specified configuration.



MAKE SURE THAT THE CONTROLLER VOLTAGE MATCHES THE INPUT VOLTAGE AND OUTPUT VOLTAGES. DO NOT APPLY POWER UNTIL THIS CONDITION IS VERIFIED.



Make sure that all conduit connections are water tight.

The output relay terminal blocks are identified as: **OUT 1 through OUT 8** these terminal blocks can be removed in the same manner as **P10**. The first four relay outputs have a N.O. and a N.C. connection, the others are N.O.

- ⚠️ Ensure the snubber's remain on each of the relay outputs in the specified wiring configuration.
- ⚠️ Unit is to be connected to supply mains by a qualified personnel in accordance with local and national codes e.g. NEC in the U.S. and CEC in Canada.
- ⚠️ A suitable power disconnection means is to be provided e.g. circuit breaker or switch which is identifiable and easily accessible to the end user.

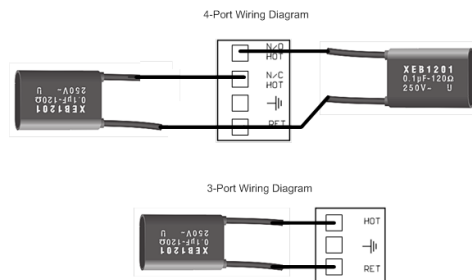

DIGITAL BOARD CONNECTIONS

The low voltage connections are found on the top board.
 Use 22-24 AWG (.76 mm²) wire for: flow switch, drum levels, dry alarm, and water meter connections. A recommended wire is OMNI cable DS92203. **These signal wires must be run separate from AC power lines.**

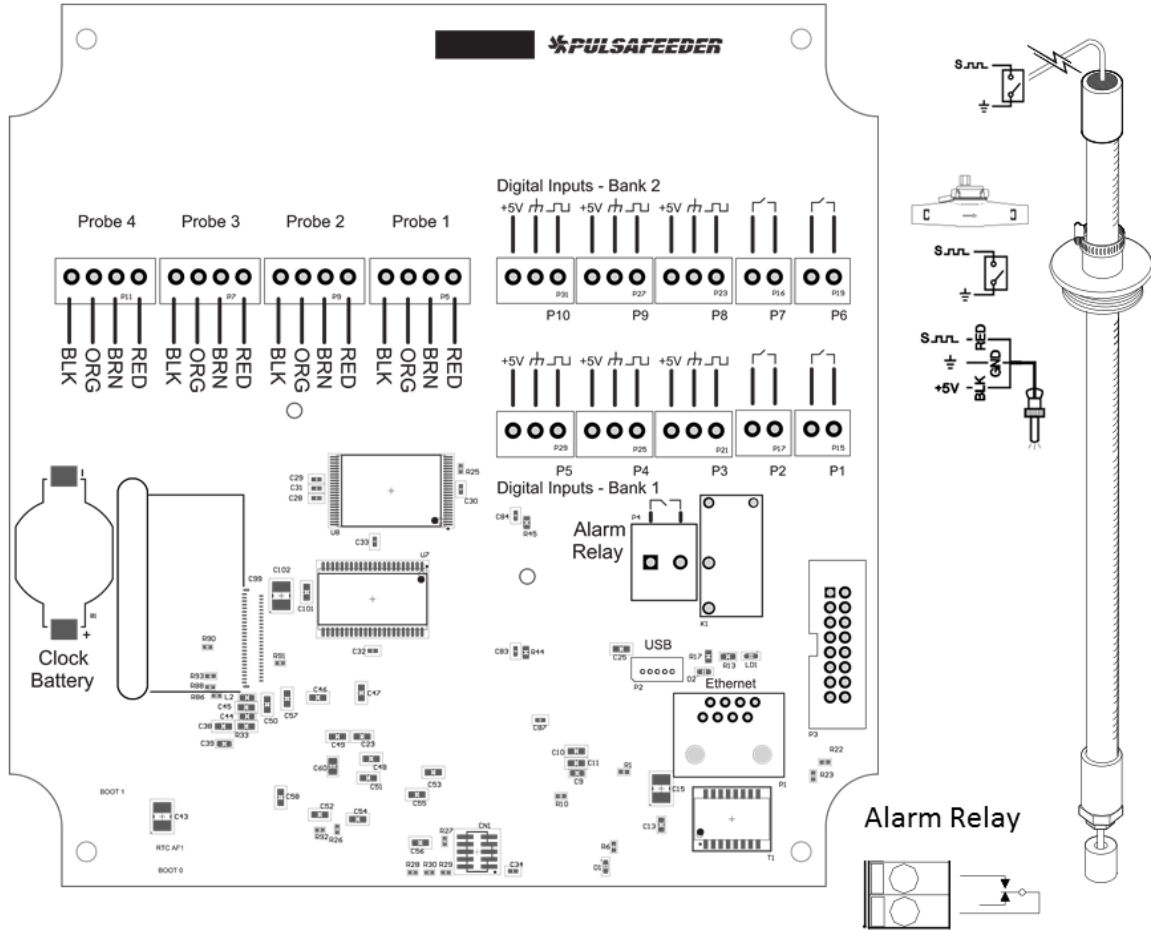

Clock Battery # 09-710-04



Low voltage signal wires, e.g., water meter, must be run separate from AC power lines.

Digital Input assignments

There are 5 digital inputs on base conductivity models and up to 10 on featured models.

Digital Inputs	Input 1	Input 2	Input 3	Input 4	Input 5	Inputs 6 & 7	Inputs 8,9 and 10
Function	Flow Switch	Drum Level #1	Drum Level #2	Drum Level #3	Water Meter	Water Meter	Water Meter
Assignment	N/A	Timer #1	Timer #2	Timer #3	WM #1	WM #2 & 3	WM #4 to #6
Location	P1	P2	P3	P4	P5	P6 and P7	P8, P9, P10
Dry Contact	✓	✓	✓	✓	✓	✓	✓
Hall Effect					✓		✓

3.8 Flow Switch Input

It is recommended that a flow switch or auxiliary dry contact be used to make outputs inoperative when the cooling tower is shut down. Connect detection wires to **P1** to use this interlock feature. This is active – closed: open = no flow; closed = flow.



If the controller does not have a flow switch, a jumper wire must be connected across **P1**.

3.9 Sensor (probe) Connection Input

The controller is supplied with sensors prewired. Depending on the model, the conductivity probe wires are connected to Probe 1, pH sensor on Probe 2, ORP sensor on Probe 3, and Make up conductivity on Probe 4.

⚠ Always depressurize the unit prior to removing a sensor.

3.10 Water Meter Input

Connect the water meter to **P5** on the top board. Some models have additional water meters on **P6** through **P10**. In order to wire a dry contact type water meter or contact closure to a 3-port digital input, connect the two leads to the signal and ground ports.

3.11 Drum Level Input

The drum level connections are labeled as, **P2** for Level 1, **P3** for Level 2, and **P4** for level 3. These are active closed: closed = low level; open = level is OK. The input can also be reversed (NO or NC) in the programming.

3.12 4-20mA Output

The 4-20mA outputs, ordered separately, can be used to remotely measure any of the controllers probe inputs and any of the 4-20mA inputs. Connect the 4-20mA receiving equipment to the 4-20mA boards pins are marked + (positive) and – (negative). The polarity must be observed for proper operation. The 4-20mA output current range is approximately 0 mA to 24mA. Resistive load range should typically be 300 Ohms with a max rating of 1200 Ohm.

3.13 4-20mA Input

Model dependent, MicroVision EX can support up to two 4-20mA analog inputs. The 4-20mA inputs, ordered separately, can be used to receive and data log signals from sensors that transmit a 4-20mA output. Connect the 4-20mA equipment to the 4-20mA boards pins are marked + (positive) and – (negative). The polarity must be observed for proper operation.

Each 4-20mA analog input supports 2 wire loop or transmitter powered configurations. Input resistance load is approximately 265 Ohms. Input voltage range is commonly 12V or 24V. Up to 60V is permissible.

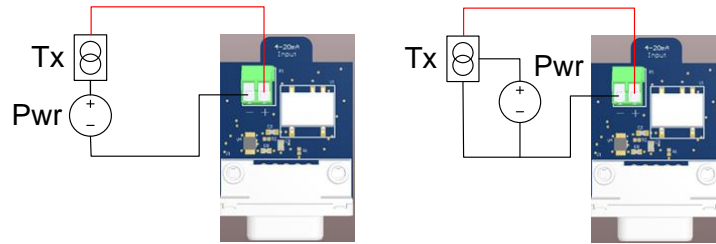

3.13.1 Fluorometer – Trace Chemical

The MicroVision EX can be optionally purchased panel mounted with a fluorometer, turner LD2 or Pyxis ST-500 probe. From the factory, the probe comes prewired and calibrated. Alternatively, the probe can be ordered separately, wired and programmed. Be sure to observe the manufacturers wiring directions.

3.13.1.1 Turner Little Dipper™ 2

The turner is an inline fluorometer with a linear 4-20mA output which responds to trace chemical. Typically is set to 4mA = 0 PPB and 20mA = 200 PPB probe has 4 wires; Red, Black, Orange, and Brown. The red is the power supply voltage. Black is the Supply ground. Orange is the positive current loop connection. Brown is the negative current loop connection. The turner little dipper 2 requires an external power supply of 8-32 VDC (1W Max)

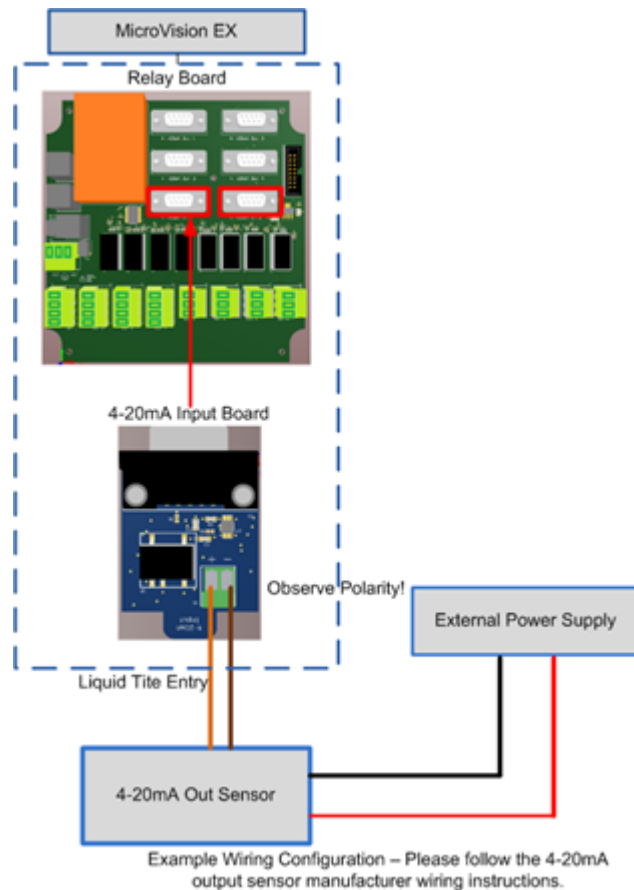

3.13.1.2 Pyxis ST-500

The Pyxis ST-500 is also an inline fluorometer which outputs both a 4-20mA signal and a RS-485 interface which responds to PTSA trace chemical. The ST-500 also has a 4-20mA where 4mA = 0 PPB and 20mA = 200 PPB. Wiring the ST-500 is similar to the Little Dipper 2. The RS-485 bus is not used by the MicroVision EX (The blue and yellow wires). The only wires necessary to terminate are power to the Pyxis and the 4-20mA loop (Brown or white (4-20mA+) and Green (4-20mA-)). The clear wire should be connected to the solution ground.

3.13.2 Calibrating PTSA Probe

4-20mA input probes require a 2 point calibration. In order to calibrate a Pyxis or Turner inline fluorometer, navigate to the 4-20mA input in question. I.E. Menu -> Settings -> 4-20mA In 1. For a PTSA probe the units are PPB. Select Type->PPB. Select Back. Scroll down to Calibrate. For a 2 point calibration you will need a low point and a high point. The best way to calibrate a low point is to put the probe in deionized water, uncontaminated with any PTSA. You should see ~4mA as the actual signal. Enter "0000" on the top line. Before exiting this page the high point will need to be calibrated. This is ideally done in the actual flow assembly. Place the probe in the flow allow solution to flow across the sensor to purge any air bubbles out of the sensor. Take a sample with a handheld meter be sure the mA signal on the controller is stable and enter the high point, the value measured by the handheld. Alternatively, to calibrate the high point of the sensor, buffer solutions can be used. Fully submerge the sensor in the known buffer ensure to expel air bubbles which may have formed on the optics. The known buffer needs to be within the range of the probes sensing capabilities. Ensure the mA output from the probe has stabilized on the MicroVision EX under the actual reading. Enter the known value as the high point, upon hitting enter on the last digit the value will be saved and your probe successfully calibrated.

3.14 Alarm Dry Contact Relay

The alarm dry contact activates for all system alarms and is a volt free signal. Use **P4** to connect the alarm reporting equipment. This relay will close when an alarm condition exists and will open when no alarm conditions are present. This connection is intended to be used to signal external process control equipment or indicators (low voltage DC operated buzzers or lamps) when an alarm condition is present. This relay is not protected by a fuse and should not be used to voltages above 48VDC.



3.15 Keypad Operation

- UP/DOWN -** Dual function keys are used to move the select (highlighted) box and to increase and decrease values.

- ○ -** Soft keys used for various functions depending on the currently displayed screen. The key's function appears above the key on the display.

3.16 Communications (Optional)

The MicroVision EX has a variety of cloud capable controllers. These controllers will ship with a CAT5 cables with an RJ45 connection. To connect the MicroVision EX to PalsaLink, Pulsafeeders cloud controller management software solution. The controller will need internet access. Please terminate the provided RJ45 connection to an open internet port.

4. CONTROLLER PROGRAMMING

4.1 Menu Map

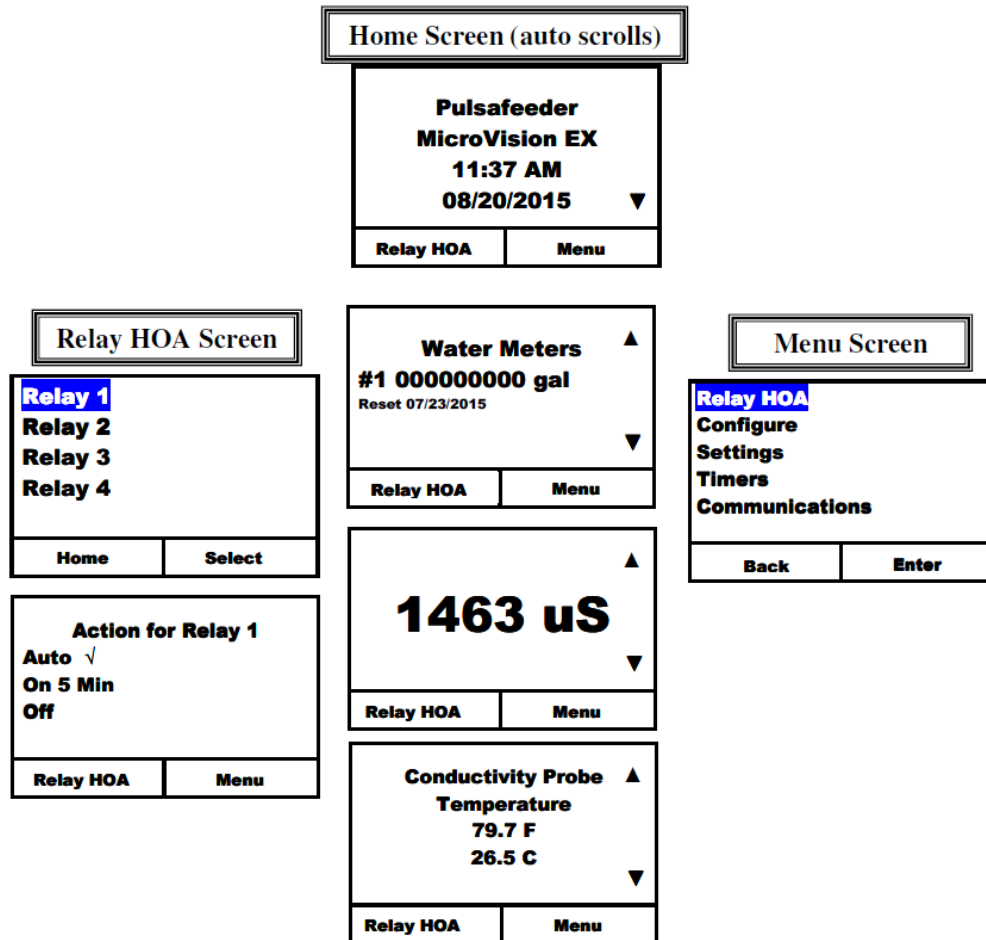

4.2 Menu Navigation

MicroVision^{EX} uses four front panel buttons to navigate through the different menus. Use these buttons to move up and down within a list of options or move right and left to enter or change parameter values. In some cases the *MicroVision^{EX}* display will prompt the user to press the different buttons to assist you in selecting or changing data. Some menus may display highlighted menu options or a checkmark (✓) next to a menu option. The highlighted menu option is used to indicate that another menu will be displayed if this option is chosen. The checkmark indicates that a particular control mode has been selected.

4.3 Home screen

The Home Screen displays the system readings and operating information. This screen is displayed during normal operation when there are no alarm conditions on the *MicroVision^{EX}*. If an alarm condition occurs an alarm message will flash on the screen. The LED's to the right of the display will also flash indicating an alarm has occurred. The *MicroVision^{EX}* will return to this screen if no buttons are pressed for five minutes after entering a menu.

4.4 Main Menu

The Main menu is the starting point for all subsequent programming menus.

Relay HOA – This menu allows for the control of the relay output states, either manual off, or auto.

Configure – This menu allows for setting the time and date, display contrast, water meter, etc.

Settings – This menu allows for setting the conductivity, pH and ORP configurations

Timers– This menu allows for setting the timers for the different feed modes.

Communications– This menu allows for exporting data, exporting settings, importing settings and upgrading the O/S.

4.5 Relay HOA

From the HOA Outputs menu manually set the relay control outputs. This is useful for servicing chemical pumps or troubleshooting electrical problems. First select the relay output to be controlled then select the relay state.



Forcing the output to Auto may cause the control output to energize without warning.

NOTE

4.6 Configure

From the Configure menu select from many different system configuration options.

Date/Time – Set the current date, date format, time, and time format.

Digital Inputs – Set the drum level settings, and water meter type and volume.

4-20mA Out- Activate or deactivate 4-20mA output options.

4-20mA In- Activate or deactivate 4-20mA input options.

Gal/Lit- Set the units that the controller displays.

Meter Totals- Display and/or reset the water meter totals.

Language – Change the controller displayed language.

Display Settings – Set the display, brightness, home screen display text, home screen scroll rate, home screen alarm message size, and the display dampener.

Password – Set the user password.

Software Version – Displays the current software version.

Factory Restore – Restore the parameters to factory default

4.6.1 Date/Time

From the Date/Time menu set the date and time as well as the date and time display formats.

Set Date – Set the current date.

Set Time – Set the current time.

Date Format – Pick the day/month/year format.

Time Format – Pick the 12-hour or 24-hour time of day format.

4.6.2 Digital Inputs

4.6.2.1 Drum Level

From the Drum Level menu select how the timer output will respond to a low drum level indication. The available choices are to allow the pump to continue to run, or have the pump stop when its drum level goes low. Drum level #1 is always assigned to timer #1, Drum level #2 is always assigned to timer #2, and drum level #3 is always assigned to timer #3.

Alarm Trigger – Program the drum level to go into alarm when the drum level switch contact is either open or closed.

Action on Alarm – Program the drum level input to either turn off the timer relay on alarm or allow it to keep the relay on in automatic mode.



When a drum level goes low the controller will go into alarm regardless of this setting. Re-filling a low drum may cause the pump control output to energize without warning.

4.6.2.2 Water Meter

From the Water Meter menu select what type of water meter the controller is attached to. Once the meter type has been entered the next setting will be for the gallons/liters per pulse or K-factor, depending on the meter type.

Dry contact or Hall-effect water meter- Once the type is selected enter the resolution or volume per pulse or pulses per gal/lit for hall effect.

Gal/pulse or K factor – enter the setting for the water meter connected.

4.6.3 4-20mA Out and 4-20mA In

Activate or deactivate the 4-20mA output or input options in this screen. Analog inputs and outputs are upgrade options for all models. To install analog signal options, first activate them in this screen, then power the unit down and then install the signal modules as described in the upgrade kit instructions. When the 4-20mA inputs or outputs are activated they will have their own program settings in the "Settings" menu.

4.6.4 Gal/Lit

Select the unit of measure for the controller to display for the water meter settings.

4.6.5 Meter Totals

In the meter totals screen view the water meter total values and the date they were last reset and reset the total values to zero in this screen.

4.6.6 Languages Menu

Select the language the controller programming displays.

- English
- Spanish
- Portuguese

4.6.7 Display Settings

This menu is for setting how the controller display appears.

4.6.7.1 Brightness

Select this menu to set how bright the background is, Low, Medium, or High.

4.6.7.2 Display Line text

Select this menu to change what text is displayed on the two lines of the main home screen display. (Pulsafeeder and MicroVision EX are the default)

4.6.7.3 Home Screen Display Scroll

Select this menu to set the speed that the home screen scrolls from displaying various values, Low (30 seconds), Medium (10 seconds), or High (5 seconds), or OFF for no scrolling of the main menu.

4.6.7.4 Display Alarm

Select this menu to set the size of the alarm messages that are displayed in the home screen when they occur.

4.6.7.5 Display Dampener

The Display Dampener setting sets how often the actual conductivity reading is updated on the Home Screen. This results in dampening of the controller response to sudden changes in conductivity.



The controller takes a conductivity reading once every second. Increasing this value above one second causes the controller to average the readings, hence, slowing down the control functions.

4.6.8 Password Setting

The Controller has two Security Access Codes, each with different system privileges - an Administrator and a User. An Administrator can access all functions of the controller. A User level can only access those items selected by the administrator. A password level is not required for access to the **home menu**.

Both passwords are active when Administrator level password is set. Conversely, both passwords are inactive when the Administrator level password is set to 000000. Each password consists of a six (6) digit numerical code.

The Administrator configures the following parameters to restrict User access to the controller systems

The following is an example of the Security menu options:

Exit Home Screen	=	Limits access to only the Home Screen.
Relay HOA	=	Allows access to the Relay HOA menu.
Configure Menu	=	Allows access to the Configure menu.
Settings Menu	=	Allows access to the Settings menu.
Timer Menu	=	Allows access to the Timers menu.

Calibration	=	Allows access to "probe Cal".
Download	=	Allows the user to export the data files.
Upload	=	Allows the user to import program settings.
USB Settings	=	Allows the user to change the USB settings.
Factory Reset	=	Restricts access to the factory reset feature.



Once the password is set the controller will require a password to access any of the menus. If the password is lost or unknown it will be necessary to call technical service to gain access to the controller menus.

4.6.9 Software Version

From the Software Version screen view the current software that is running in the *MicroVision^{EX}* controller.

4.6.10 Factory Reset Function

The Factory Reset Function will reset all of its internal parameters to the factory default values.



Be absolutely certain you want to reset all the parameters back to the factory defaults. Once the reset takes place there is no way to retrieve the previous parameters.

4.7 Settings

The Settings menu is for setting the control parameters for conductivity, pH and ORP.

4.7.1 Conductivity

Set point Type - A Set point is a setting at which the controller activates an output, such as a solenoid valve or a metering pump on the relay outputs or dry contact outputs. The type – **Rising** or **Falling** defines which side of the set-point the relay activates. A **Rising** type means that the output activates when the input goes above the set point. A Rising set point is commonly used in conductivity control where you want to keep conductivity below a certain value. A **Falling** type activates the output when the value goes below the set point.

Set point –This is the conductivity point where a bleed function will begin.

Differential – The differential setting controls when the bleed function stops. This value subtracted from the conductivity set point causes the bleed function to stop.

Example: Rising Set point=1200, Differential=100, the bleed function begins when the conductivity reaches 1200 and ends when the conductivity reaches 1100.

Limit Timer – Set this value to the maximum amount of time the bleed output can stay energized before a Bleed Limit alarm is reported. If the next bleed cycle completes without an alarm the alarm will clear itself on the next cycle. Setting the limit timer value to 00:00 will turn off limiting function of the relay.

Limit Alarm- Use this option to turn the control relay off on a limit alarm, or to keep it on in automatic mode during a limit alarm. (default is “keep relay on” for the bleed relay)

Probe Calibration – Use this function to calibrate the probe.

Alarm Setp’t – Use this menu to specify the upper and lower values for alarm reporting.



Settings Menu- When the settings menu is being displayed, probe control operations stop until all settings changes are completed and



The conductivity probe is very sensitive to temperature changes. Allow the probe roughly 10 minutes to adjust to the temperature of the test solution or sample. Calibrating the probe without allowing the probe to equilibrate to the sample temperature could result in erroneous controller conductivity readings.



Only use a calibration meter that incorporates temperature compensation when performing a probe calibration.

4.7.1.1 Probe Calibration Conductivity

Because there are no metal electrodes to foul re-calibration is not required for the toroidal probe on a regular basis. However, you may want to calibrate the probe initially to get a base-line reading for future reference or to have the reading match a hand held tester. There are two methods of probe calibration that can be used to calibrate this probe.

- In-stream Calibration** – In this method the probe is already installed in the process flow and is currently reading conductivity. Be certain adequate flow (1 gallon/minute minimum) has been circulating around the probe for at least 15 minutes. This will ensure the probe temperature has stabilized and a more accurate conductivity reading will be made.

Step 1 – Move to the Probe Calibration screen.

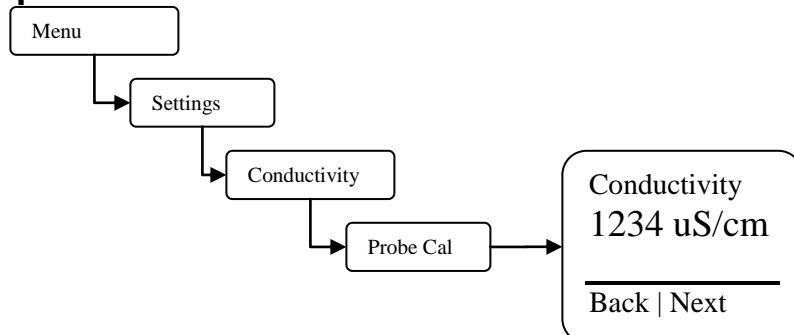

Step 2 – Draw a sample of the process flow water and measure the conductivity using a calibrated meter. Be certain the meter being used to measure conductivity is temperature compensated.



Do not allow the sample to sit for any length of time after being drawn as this may cause the reading of the sample to be different from the probe.

Step 3 – Enter the calibrated conductivity value into the Probe Calibration screen.



If the conductivity reading varies more than 25 counts from the reading of the calibration meter verify the sample temperature is within $\pm 1^{\circ}$ C of the probe temperature.

Step 4 – Return to the Home Screen and verify the proper conductivity reading is displayed.

4.7.2 pH and ORP

From these menus configure the parameters that trigger the pH and ORP control output. Additionally, the probe calibration, alarm set points, and the limit timer functions are also configured in this section.

Set point Type - A Set point is a setting at which the controller activates an output, such as a solenoid valve or a metering pump on the relay outputs or dry contact outputs. The type – **Rising** or **Falling** defines which side of the set-point the relay activates. A **Rising** type means that the output activates when the input goes above the set point. A Rising set point is commonly used in pH control where it is desirable to keep pH below a certain value. A **Falling** type activates the output when the value goes below the set point. A common example of this is ORP control, where maintaining a certain minimum level of an oxidizer in the system is required.

Set point – This is the point where a control relay will activate. Once the pH or ORP has reached this value the control relay output will turn on.

Differential – The differential setting controls when the control relay deactivates. This value subtracted from the set point causes the relay to stop.
Example: Set point=7.00, Differential=1.00, the pH begins when the pH reaches 7.0 and ends when the pH reaches 6.0.

Limit Timer – Set this value to the maximum amount of time the output can stay energized before a pH or ORP Limit Alarm is reported. If the next control cycle completes without an alarm the limit alarm will clear itself on the next cycle. Setting this value to 00:00 turns off this function.

Limit Alarm- Use this option to turn the control relay off on a limit alarm or to keep it on in automatic mode during a limit alarm. (default is "Turn relay off" for the pH and ORP relay)

Probe Calibration – Use this function to calibrate the probe.

Alarm Setp't – Use this menu to specify the upper and lower values for alarm reporting.



The probe is very sensitive to temperature changes. Allow the probe roughly 5 minutes to adjust to the temperature of the test solution or sample. Calibrating the probe without allowing the probe to equilibrate to the sample temperature could result in erroneous controller readings.

4.7.2.1 pH and ORP Probe Calibration (1 point)

Probe Calibration – Use this function to calibrate the probe. Enter the calibrated value based on the calibration method used. For both methods shown below the actual reading from the probe is shown on the screen. This is the un-calibrated value the controller is receiving from the sensor. If the actual value displayed in the calibration screen is not close to the sample that the probe is actually in, or the reading is changing significantly, the probe either needs to be cleaned or replaced, or the solution the probe is in is no longer accurate. Typically ORP does not require a calibration for most applications for that reason only pH is illustrated below.

In-Stream (Best Practice)

Begin with a clean sensor. With the pH or ORP sensor installed in the system under normal operating conditions ensure flow is going across the probe for at least five (5) minutes for temperature equilibrium.

Step 1 – Move to the Probe Calibration screen.

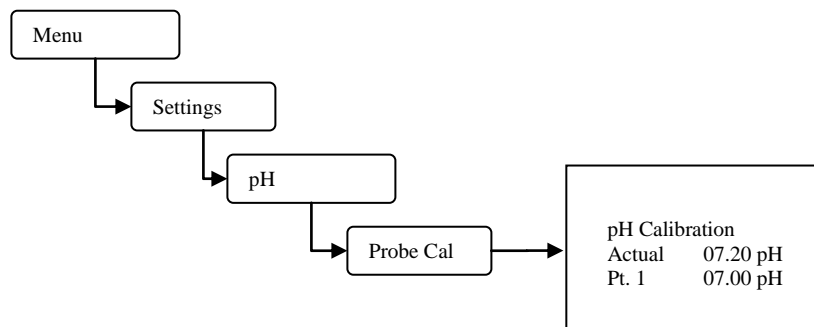

Step 2 – Take a reading with a hand held tester from the sample valve on the controllers flow assembly.

Step 3 – Observe that the actual reading displayed has stabilized then enter the reading from the hand held tester as point 1. For the best results, this method should be done with the system operating at, or within 1 pH unit, of the pH set point.

Step 4 – Return to the Home Screen and verify the proper pH reading is displayed.

Standard solution

Begin with a clean sensor, rinse the sensor with the standard solution to be used for calibration purposes three (3) times, place the sensor in a standard solution that represents the side of the pH scale for intended control. For example, if the set point is above 7pH the standard should also be above 7pH. With the sensor in the solution for at least five (5) minutes for temperature equilibrium, observe that the actual value displayed has stabilized and then enter the standard solution value as point 1.

4.7.3 4-20mA Outputs (Optional Accessory)

To enable 4-20mA output, see sec 4.6.3. The output will then be configurable from the settings page. First set the type setting to the sensor input that the 4-20mA output will track, any probe types can be configured. Then enter the sensor reading ranges to scale the 4-20mA output to. Any sensor value can be entered for the 20.0 and 4.0mA ranges. The actual output can then be adjusted from 20mA to 24mA and from 0mA to 5mA for calibration to the receiving device.

4-20mA Out 1 = Cond.	
9999 uS = 20.0 mA	
0000 uS = 4.0 mA	
Min. diff. = 1000 uS	
Back	Next

4.7.4 4-20mA Inputs (Optional Accessory)

To enable a 4-20mA input, see sec 4.6.3. Once the board is enabled device will appear in the settings page. Here you can setup the peripheral. To setup you must configure the type and calibrate the input. To configure the type select the mode which resembles your application. Then you must calibrate the input, depending on the input type, you may need buffer solutions to do this. Hold the input device in a low state, enter the correlating value in the controller on the top line, do not exit the setup until the next point has been calibrated, otherwise you will get an error. Place the input in a high state and enter the correlating value in the controller. Your input should now be set-up. If you still get an error exit out and start over. If you wanted to have any timers trigger based on the 4-20mA input you can configure a set point control timer.

4.8 Timers - Modes

From this menu pick the mode that the timer will follow.

Pulse Timer – Runs the timer based in inputs from a water meter.

Percent Timer – Sets the Timer to run on a repeating cycle. Set the Cycle time period and percentage of the cycle time period to run for. Example: Cycle Time=60minutes, % Minutes to run=10, the timer will run for 10% of 60 minutes, or 6 minutes every 60 minutes.

28-day timer- Runs the timer based on a calendar schedule of specific times, days, and weeks. Typically used to add biocides

% Post Bleed – Runs the timer for a percentage of the bleed time when the bleed control stops.

Limit Timer – Set this value to the maximum amount of time for the timer to run while the bleed function is running. If this time is exceeded the controller will go into alarm and the timer control output will de-energize.

Alarm – The timer activates based on system alarms for powering sirens, lights or sending remote signals.

Set-point Control – This timer behaves like a conductivity, pH and ORP relay. The relay will turn on and off based on a probe input set-point.

Disabled – The timer does not activate.

4.8.1 Timers – Pulse Timer

From this menu configure how the timer will run while in pulse timer mode. This mode uses the water meter input to cause a counter to accumulate a certain volume of water before the timer is activated. Once the accumulated volume is reached, the timer is activated for the programmed Feed Time.

Feed Time – Set this value to the amount of time for the timer to run when the water meter **accumulator count** reaches the **accumulator set**.

Accumulator Set – Set this value to the amount of water that needs to accumulate prior to a timer feed time. The units will be in gallons or liters depending on what units are set in the configure menu.

Accumulator Count – This is the current running count of the water meter accumulator.

4.8.2 Timers – Percent Timer

From this menu configure the timer to operate on a percentage of a fixed cycle time repeatedly.

Example:

Cycle Time=60minutes.

% Minutes to run=10%

In this example the timer will feed for 10% of 60 minutes, or 6 minutes every 60 minutes.

4.8.3 Timers - 28 day (Biocide Timer)

From this menu configure how often and the duration for the biocide 28-day timer to run. This controller can also perform a pre-bleed, using a conductivity minimum with a fixed time, and a bleed-lockout function for each biocide feed program. Each 28 day timer has four (4) programs (Program A to D) with individually programmable settings as follows:

Days/Weeks – Set the days and weeks for the timer to run.

Start Time – Set the time of day for the timer to begin. If a pre-bleed is programmed, this is the time that the pre-bleed starts. Setting the value to 00:00 means the start time is ignored.

Feed Time – Set this value to the amount of time for the timer to activate the timer control relay for each start time.

Pre-Bleed – Set the pre-bleed time to the maximum amount of time for the pre-bleed function to force a bleed cycle without reaching the conductivity minimum. Set the conductivity minimum to the value for the conductivity to reach before the bleed cycle finishes and the biocide feed time.

Bleed Lockout – Set this value to the amount of time to lock-out a bleed function during (and after if set longer than the feed time) a biocide feed cycle.



28 day timer programs (A to D) cannot be set to run at the same time, week and day. If two timers have the same run times only the first program, in alphabetical order, set will run (example if A and B are the same, only A will run.)

4.8.4 Timers – % Post Bleed

From this menu configure how the timer will run while in percent post bleed mode. This mode uses the bleed time to calculate the run time based on a user defined percentage setting.

Percentage – Set this value to the amount of time (as a percentage) for the timer to run after a bleed function has completed.

Example: % of Bleed=25%, the most recent bleed cycle took 20 minutes, the timer will now feed for 25% of 20 minutes, or 5 minutes.

Limit Time – Set this value to the maximum amount of time to allow the timer to run after a bleed cycle has completed. Setting the timer to 00:00 turns off this function.

4.8.5 Timers – Limit Timer (Bleed and Feed)

From this menu configure how the timer will run with the bleed relay. This mode activates the timer at the same time as the bleed time up to a user defined maximum time. Set this value to the maximum amount of time to allow the timer to run for during bleed cycle. Setting the limit timer value to 00:00 will turn off limiting function of the relay.

4.8.6 Timers – Alarm

In this mode the timer activates with any system alarm condition.

4.8.7 Timers – Set Point Control Mode

A set point control mode time can be pointed to any of the probe inputs. Programming the timer mode is identical to setting up a probe. This timer mode is only an option on timer 1, 2, and 3. One of the core functions of this timer mode is to feed chemical in response to a 4-20mA probe time, a PPB or PPM type input.

Set point Type - A Set point is a setting at which the controller activates an output, such as a solenoid valve or a metering pump on the relay outputs or dry contact outputs. The type – **Rising** or **Falling** defines which side of the set-point the relay activates. A **Rising** type means that the output activates when the input goes above the set point. A Rising set point is commonly used in conductivity control where you want to keep conductivity below a certain value. A **Falling** type activates the output when the value goes below the set point.

Set point –This is the defined point where a relay will energize.

Differential – The differential setting controls the offset which the relay will remain energized, once the offset is exceeded the correlating relay will de-energize.

Limit Timer – Set this value to the maximum amount of time relay will remain on until an alarm is triggered. Setting the value to 00:00 disables the timer.

Limit Alarm- Use this option to turn the control relay off on a limit alarm, or to keep it on in automatic mode during a limit alarm. (default is “keep relay on”)

Alarm Setp't – Use this menu to specify the upper and lower values for alarm reporting.

4.8.8 Timers – Disabled (Default)

In this mode the timer does not activate other than by the use of the HOA function.

4.8.9 Timers – Bio Tracking (In All Timer Modes)

From this menu configure how the timer will respond when a 28-day timers **Feed Time** setting is running.

Skip – Choose this option for the timer to skip a feed cycle if a 28 day biocide timer happens to be feeding.

None – Choose this option for the timer to run regardless of what the biocide feed cycles are doing.



Any timer feed time that was skipped due to a 28 day biocide feed cycle will not be added to the next timer feed cycle.

4.9 Communications

The controller has two primary methods of communications, a direct USB collection port and an Ethernet port.

4.10 USB

When a USB flash drive is inserted into the USB cable the user can take certain actions. If a password has been entered into the controller, the user must first enter the required code to access the USB options screen.

Export Data Log

The controllers data log history file can be downloaded to the USB flash drive in CSV format.

Export Config File

The controllers programming and set points can be down loaded for duplication of the program on other *MicroVision^{EX}* controllers or as a record of the current settings.

Import Config file

The controllers programming and set points can be uploaded for duplication of the program from other *MicroVision^{EX}* controllers.

Erase Data Log

Use this function to reset the controllers data log records. The current data log will be erased and cannot be recovered

Data Log Name

Use this setting to give the exported data files a unique file name for each controller. The file name length is fixed at 16 characters. However, it is

possible to use "*" symbols in the name to create spaces. The default name is: DataLogFile***** this produces CSV file named DataLogFile0.csv

Data Log Interval: Use this setting to define how much data the controller will store. Options are "Custom", 30 days, 60 days, 90 days, 120 days, 1 year or 2 years. All Data Log Interval ranges still record controller data every 1 minute; however the "custom" setting allows for a range from 2 to 120 minutes to make exporting the data file to a USB drive or downloading faster. Because the custom range always uses the same size memory block it stores various ranges of data.

Example:

Custom range @ 2 Minutes = 60 Days
Custom range @ 120 minutes = 9.8 Years

Normal data log interval settings create a file that could be as large as 350MB in size. The custom range settings create a file that could be as large as 40MB.



In order to access the data stored on the controller remotely the data log interval must be set in either 30 days @ 1 minute or any setting in the custom menu.



Changing the Data log interval erases the existing data log file in the controller to create a new one. To avoid losing data, download the current log file before changing this setting.

Operating System Upgrade

The controllers operating software can be updated in the field to the most current version available. To upgrade the OS install the OS file on a USB drive and plug the drive into the controller. Make a note of all controller program settings, and then power the controller down. Press the Arrow up key and the lower left navigation key (upper right and lower left keys diagonal from each other) on the front panel and hold them down. Next power the controller up. Wait approximately 30 to 60 seconds, the controllers display will come on and the new OS will be installed. Before programming erase the data log and perform a factory reset. Reprogram the controller settings.

4.10.1 USB Graphing Tool

The MircoVision EX data log file is output as a CSV file. This file can be opened for easy viewing and digestion of data using our provided graphic tool. Visit: www.pulsatron.com/support/pulsaworks to download.

4.10.2 USB Data log Timer and Tamper Codes:

Timer Modes

1792 = Disabled
1536 = Alarm
1280 = Set Point control
1024 = Limit Timer

768 = % Post Bleed Timer
512 = 28 day Biocide Timer
256 = Percent Timer
0 = Water Meter Pulse Timer

TMPR Column:

The tamper column will nominally appear as 0. If the unit is tampered with you will see a 1 in the tamper column. Any other value indicates a power cycle of the unit.

4.11 Ethernet (Optional)

On a model equipped with Ethernet communications, the *MicroVision^{EX}* controller when networked via the Ethernet cable and an application appropriate network adapter the user will be able to access the controller, download data from the unit and upload programming changes via our online PalsaLink portal.

4.11.1 Programming your controller PalsaLink

Once the controller's RJ45 connector has been wired to a reliable Ethernet connection. The controller has a token which needs to be programmed. After setting the controller token to a non-zero value (Menu->Communications->Networking->Token) power cycle the controller to start communicating on PalsaLink. The default token is 000-000-001. See the PalsaLink user manual for more information.

4.11.2 Setting Up Your Controller on PalsaLink

In order to access your controller online you will need to go to "<https://www.palsalink.net/login>". Contact your company administrator if you need to be setup with an account. An administrator needs to grant access to users to each controller.

5. FACTORY DEFAULTS

	DEFAULTS
SYSTEM CONDUCTIVITY SCALE	0-9,999 μS/CM
Set point Type	RISING
Set point	1500 μ S/CM
Set point Differential	50 μ S/CM
High Alarm	1700 μ S/CM
Low Alarm	1300 μ S/CM
Limit Timer	00:00 (disabled)
MAKE-UP CONDUCTIVITY SCALE	0-10,000 μS/CM
Set point Format	CYCLES
Set point Scale	0-2000 μ S/CM
Set point Ranges	0-400 / 401-800 / 801-1200 / 1201-1600 / 1601
Set point Range Set points	6.0 / 5.0 / 4.0 / 3.0 / 2.0 Cycles
Set point Differential	40 μ S/CM
High Alarm	840 μ S/CM
Low Alarm	360 μ S/CM
SYSTEM pH SCALE	0-14 pH
Set point Type	Rising
Rising Set point	7.8 pH
Set point Differential	0.2 pH
High Alarm	8.3 pH
Low Alarm	6.3 pH
Limit Timer	01:30
SYSTEM ORP SCALE	-2000+2000 mV
Set point Type	FALLING/LOW
Set point	400 mV
Set point Differential	50 mV
High Alarm	500 mV
Low Alarm	300 mV
Limit Timer	01:30
4-20mA INPUT	NONE
Units	NONE
4-20mA OUTPUT	0-20 mA
Type	None
LEVEL INPUT	
Type	Level Keep Relay on
FLOW INPUT	
Type	Flow
TIMER	
Type	DISABLED
TIMER: LIMIT	
Run Time	01:30 HH:MM

TIMER: PERCENT

Percent 0%
Percent Minutes 10

TIMER: PERCENT POST BLEED

Bleed Percent 0%
Maximum Time 01:30 HH:MM

TIMER: PULSE

Run Time 00:30 MM:SS
Pulse Set 10
Water Meter One

TIMER: 28-DAY

Run Time 01:30 HH:MM
Lock Out 00:00 HH:MM
Pre Bleed 00:00 HH:MM
Conductivity Minimum 0 μ S/CM
Program: Start Time 00:00 HH:MM
Program: Week EVERY WEEK
Program: Day NO DAY

WATER METER

Gallons per Pulse 100

Scroll rate High (3 seconds)

SECURITY

Passwords (NONE)

6. TROUBLESHOOTING GUIDE

Symptom	Probable Cause	Possible Solution
Controller does not power up.	No power supplied to controller.	Insure that correct voltage is supplied to controller.
		Check circuit breaker supplying power to the controller.
	Fuse is blown.	check/replace fuses (see page 9)
	Ribbon cable.	Check ribbon cable connecting upper and lower pc boards inside controller.
Controller displays "Flow Switch Alarm" alarm message.	No flow thru flow assembly.	Insure there is enough water flow through the assembly. At least 1 GPM (3.8 LPM) of flow.
	Flow switch wiring or connector loose.	Check flow switch connections
	Flow switch stuck.	Clean flow switch sensor mechanicals.
	Flow assembly clogged.	Clean inside flow assembly.
	Flow switch input jumper missing.	Install jumper if flow switch is not used.
Controller displays "Limit" alarm message.	Programmed limit timer set too short.	Adjust limit timer value to longer duration
	Clogged bleed valve or drain.	Clean valve or drain.
	Faulty bleed valve.	Replace bleed valve.
Controller displays "Probe Comm" alarm message.	probe wiring or connector loose.	Check probe connections
	Bad Conductivity probe	Replace probe.
Controller displays "Bleed Limit" alarm message.	Conductivity Limit timer set too short.	Adjust limit timer.
	Bleed valve/drain failure.	Clear obstruction around drain.
Conductivity, pH or ORP reading on controller does not match portable hand-held reading.	reading is within specification.	Due to variations in hand-held meters, standard solutions, temperature compensation, and the controller's accuracy of +/- 2%, the reading on the controller may not match that of your hand-held

7. MAINTENANCE

The only recommended maintenance required on the controller is periodic inspection of the conductivity sensor every 6 months. It is recommended to establish a regular maintenance schedule designed to meet the needs of each particular application. All other service should be performed by factory authorized personnel only. Modifications to or tampering with the circuit level components makes all warranties, written or implied, and/or manufacturer's responsibility for this controller, null and void.



DISCONNECT POWER BEFORE OPENING THE UNIT TO ACCESS FUSES. MAKE SURE THAT REPLACEMENT FUSES ARE OF SAME TYPE TO MAINTAIN SAFETY APPROVALS.

⚠ ALWAYS DEPRESSURIZE UNIT BEFORE REMOVING PROBES

FUSE	TYPE
F1 & F3	5 X 20mm, 8A, 250V (Output power)
F2	5 x 20mm, 1A 250 V (Input power)

7.1 Conductivity Sensor removal and cleaning

To remove the conductivity sensor from its tee for cleaning:

1. Remove power to the system.
2. Remove pressure from the system prior to unscrewing the sensor by closing the hand valves located before and after flow assembly.
3. Open the sample port; this will facilitate removal of sensor.
4. Unscrew the coupling nut.
5. Remove the sensor.

To clean conductivity sensor:

1. Wipe the sensor with a clean cloth.

7.2 pH sensor Information

The combination pH sensor supplied with your controller is designed for maximum reliability, accuracy, and ease of use. The reference half-cell is sealed and non-refillable. The sensor is shipped with a protective boot or bottle filled with a junction wetting agent.

7.2.1 Preparation

Remove the lower portion of the protective boot and rinse the sensor tip with tap water. It is possible that air bubbles may have migrated into the pH sensitive bulb during shipment. The sensor is unable to function with air in the bulb. To remove air, gently shake the sensor downward in the same manner as a clinical thermometer. Prior to first usage or after long-term storage, immerse the lower end of the sensor in tap water for thirty minutes. This hydrates the pH bulb and prepares the liquid junction for contact with the test solution. Occasionally during long-term storage or shipment, the sensor may develop a film on the pH bulb. The film may be removed by following sensor cleaning instructions.

7.2.2 Sensor Storage

To maintain response, sensors should always remain wet. The preferred storage solution is pH 4.0 buffer with saturated KCl added. Tap water will suffice for short term storage. Do not soak in distilled water. The supplied storage boot or bottle will provide an ideal chamber for lengthy storage

7.2.3 Sensor Cleaning

Sensors which are mechanically intact can often be restored to full response by the following procedures:

1. Inorganic Scale Deposits. Dissolve the deposit by immersing the sensor first in 0.1M HCl (hydrochloric acid), then in 0.1M NaOH (sodium hydroxide), and again in 0.1M HCl. Each immersion should be for a 5-minute period.
2. Organic Oil or Grease Films. Wash sensor tip in a liquid detergent and water. If film is known to be soluble in a particular organic solvent, wash with this solvent. Rinse sensor tip in tap water.

If these procedures fail to rejuvenate the sensor, the problem is most likely a clogged liquid junction. Cleaning the liquid junction involves heating a diluted KCl (Potassium Chloride) solution to 60-80°C (139-176°F). Place sensor tip in the heated KCl solution for approximately ten minutes. Allow the sensor to cool while immersed in the solution before re-testing. If these steps fail to improve the sensor response, replace the sensor.

7.3 ORP Sensor Information

The ORP option provides monitoring and control with a control setpoint in millivolts (mV).

7.3.1 ORP Maintenance and Troubleshooting

ORP standard buffers of 100mV and 465mV are readily available, making it easy to standardize ORP systems against buffers. Like pH sensors, ORP sensors are subjected to coating and abrasion by the measured liquid and, in certain instances, are "poisoned" by chemicals which may be present if the system goes out of control. To improve the reliability of ORP measurement and control, the following is a means of testing sensors in solutions of standard potential, which will determine if sensors are responding correctly or need maintenance attention.

7.3.2 Testing ORP Sensor

Solution A: Use sufficient 100mV buffer to immerse sensors. Potential should be within +/- 10.

Solution B: Remove sensors and rinse thoroughly with water. Immerse sensors in 465mV solution. There should be a rapid response.

The millivolt difference between the two solutions is theoretically 365mV. The absolute values may shift upward or downward a few millivolts due to slight variations from theoretical potential by the reference sensor.

If system potentials are correct, flush sensors with deionized water and measure the liquid in question. If incorrect by more than 10 mV, sensors should be cleaned with aqua regia (three volumes hydrochloric acid, one volume concentrated nitric acid.) Repeat above tests. Once satisfactory readings are obtained, install sensors and make measurements of liquid in question.



Use proper handling procedures including rubber gloves, eye protection and protective clothing, when handling any acid solution.

7.3.3 Flow Sensor

The Flow Sensor uses differential pressure to cause a shuttle to rise and magnetically activate a reed switch. Occasionally this assembly may become fouled, preventing the shuttle from rising and/or falling.

To clean the assembly:

1. Close isolation valves and relieve system pressure from the flow assembly.
2. Remove flow cap by loosening retaining nut. Remove flow cap from flow body by pulling straight out.
3. Remove red shuttle by pulling straight out. Note post shuttle rides on.
4. Clean all internal surfaces of flow body with soft bristle bottle brush. Be careful of the post that the shuttle rides on, its surfaces must be clean, but do not break it while cleaning.
5. Clean shuttle exterior surfaces and shuttle bore with a soft brush. You may use a mild dish soap if desired. Flush well before re-installing.
6. Re-install shuttle and attach flow cap. Open isolation valves. Check for leaks.

8. SPECIFICATIONS

Controller	
Enclosure	IP65
Power supply	120 or 220 VAC; 50/60Hz.
Reading Accuracy	+/- 2% at point of measure
Maximum relay output current	120 VAC: 8 A Resistive/General use. 4LRA/4FLA, 1/10HP (motors) 220 VAC: 8 A Resistive/General use. Not rated for motors
Probe	
Maximum temperature	122° F (50°C)
Temperature compensation range	32°F - 122°F (0° - 50°C)
Maximum pressure	125 PSI (8,6 BAR)
Probe type	Toroidal Conductivity, standard pH and ORP
Maximum cable length	100 Feet (30,5 Meters)
Materials of construction	Polypropylene
Conductivity reading	0-9999 uS/cm; 1 uS/cm increments
pH reading	0.00 to 14.00
ORP	-2000mV to +2000mV
Flow Switch	
Maximum temperature	127°F (52°C)
Maximum pressure	125 PSI (8,6 BAR)
Activate flow rate	Approximately 1 GPM (3,785 LPM)
Materials of construction	PVC and Glass filled Polypropylene

9. FORSEABLE MISUSE

The unit has many relays which can be programmed to operate on a variety of inputs and timers. It is important to verify the system is set up properly through testing, and that relays are actuated by the correct timer or input. It is important to verify all unit readings match a known value. Operating outside design intent may cause hazard. Connecting receptacles to unapproved hardware, i.e. drills, power tools, motor driven pumps, may cause a hazard. Use only as directed. Unit has been designed for cooling tower applications and any other application should be discussed with the factory prior to install. Do not operate off of another controller. Do not use with extension cords.

10.MOUNTING HOLE PATTERN (Footprint)

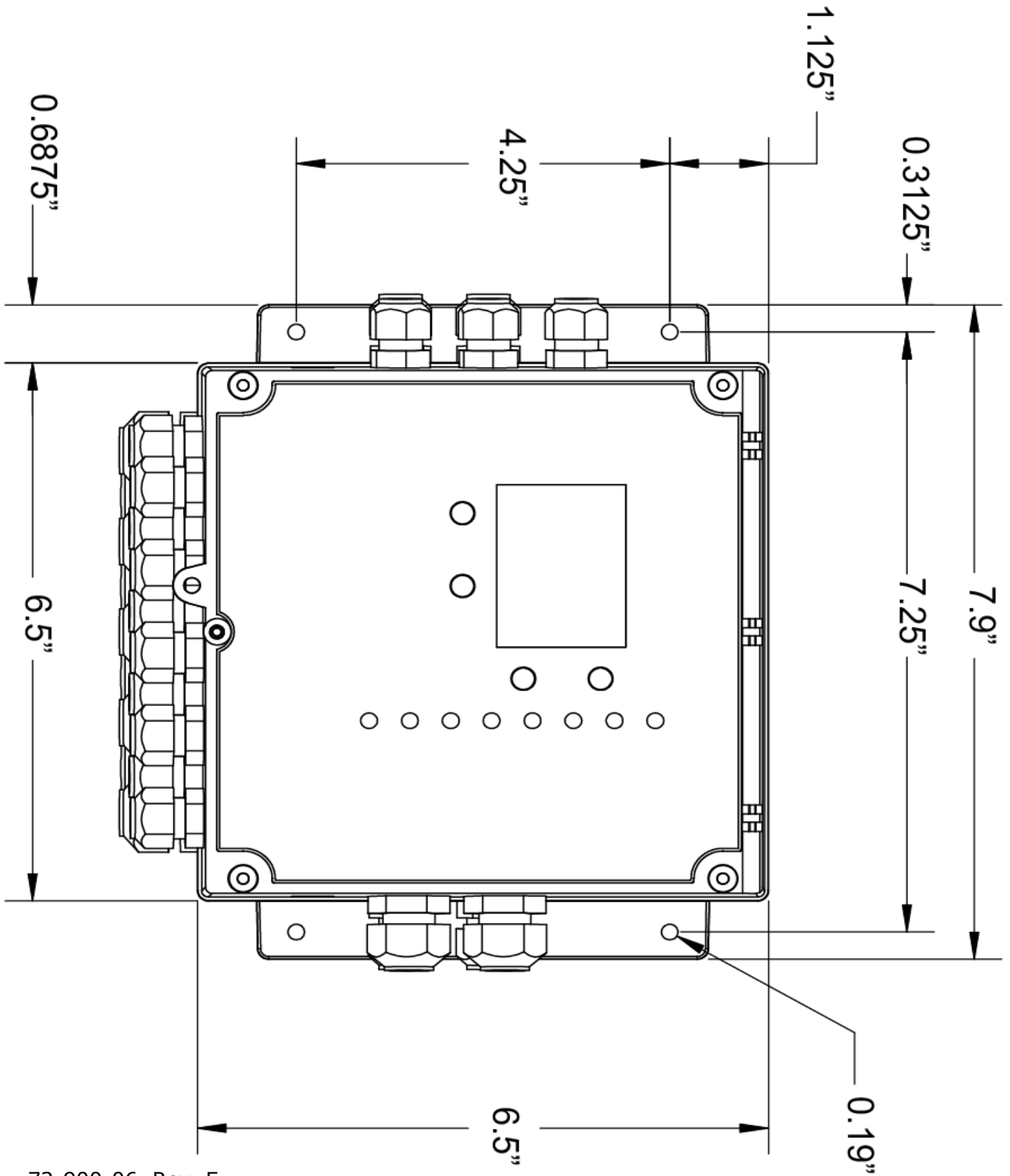

Factory Service Policy

The *MicroVision^{EX}* is a state of the art microprocessor based controller. If you are experiencing a problem with this instrument, first consult the troubleshooting guide in this manual. If the problem is not covered or cannot be solved, contact Technical Services for assistance:

PULSAFEEDER INC. (SPO)
27101 AIRPORT ROAD
PUNTA GORDA, FL 33982
941-575-3800

Trained technicians are available to diagnose your problem and arrange a solution. Solutions may include purchase of replacement parts or returning the controller to the factory for inspection and repair. All returns require a Return Authorization number to be issued by Pulsafeeder. Parts purchased to correct a warranty issue may be credited after an examination of original parts by Pulsafeeder. Warranty parts returned as defective which test good will be sent back freight collect. No credit will be issued on any replacement electronic parts.

Any modifications or out-of-warranty repairs will be subject to bench fees and costs associated with replacement parts.

Warranty

Pulsafeeder, Inc. warrants control systems of its manufacture to be free of defects in material or workmanship. Liability under this policy extends for 24 months from date of shipment including the toroidal sensor. Electrodes/probes other than the toroidal conductivity sensor are considered maintenance items and as such are warranted for six (6) months from the date of shipment of the controller. Electrodes/probes purchased as spare parts are warranted for 90 days from date of shipment. The manufacturer's liability is limited to repair or replacement of any failed equipment or part, which is proven defective in material or workmanship upon completion of the manufacturer's examination. This warranty does not include removal or installation costs and in no event shall the manufacturer's liability exceed the selling price of such equipment or part.

The manufacturer disclaims all liability for damage to its products through improper installation, maintenance, use, or attempts to operate such products beyond their functional capacity, intentionally or otherwise, or any unauthorized repair. The manufacturer is not responsible for consequential or other damages, injuries, or expense incurred through the use of its products.

The above warranty is in lieu of any other warranty, whether expressed or implied. The manufacturer makes no warranty of fitness or merchantability. No agent of ours is authorized to provide any warranty other than the above.



USA

Pulsafeeder, Inc.
27101 Airport Rd.
Punta Gorda, FL 33982
USA
(941) 575-3800
www.pulsatron.com

European Union (EU)

Pulsafeeder-Europe
Via Kennedy, 12-20090
Segrate—Milano— Italy