

# SERVICE & OPERATING MANUAL

ORIGINAL INSTRUCTIONS

# VDA

## VPD05, VDA07, VDA10

Metallic and Non-Metallic Surge Dampeners



**VERSAMATIC®**  
ACCESSORIES

# Safety Information

## IMPORTANT



Read the safety warnings and instructions in this manual before pump installation and start-up. Failure to comply with the recommendations stated in this manual could damage the pump and void factory warranty.



When the pump is used for materials that tend to settle out or solidify, the pump should be flushed after each use to prevent damage. In freezing temperatures the pump should be completely drained between uses.

## CAUTION



Before pump operation, inspect all fasteners for loosening caused by gasket creep. Retighten loose fasteners to prevent leakage. Follow recommended torques stated in this manual.



Nonmetallic pumps and plastic components are not UV stabilized. Ultraviolet radiation can damage these parts and negatively affect material properties. Do not expose to UV light for extended periods of time.

## WARNING



When used for toxic or aggressive fluids, the pump should always be flushed clean prior to disassembly.



Before maintenance or repair, shut off the compressed air line, bleed the pressure, and disconnect the air line from the pump. Be certain that approved eye protection and protective clothing are worn at all times. Failure to follow these recommendations may result in serious injury or death.



Airborne particles and loud noise hazards. Wear eye and ear protection.



In the event of diaphragm rupture, pumped material may enter the air end of the pump, and be discharged into the atmosphere. If pumping a product that is hazardous or toxic, the air exhaust must be piped to an appropriate area for safe containment.



Take action to prevent static sparking. Fire or explosion can result, especially when handling flammable liquids. The pump, piping, valves, containers and other miscellaneous equipment must be properly grounded.



This pump is pressurized internally with air pressure during operation. Make certain that all fasteners are in good condition and are reinstalled properly during reassembly.

# Table of Contents

## **SECTION 1: PUMP SPECIFICATIONS.....1**

- Dimensional Drawings

## **SECTION 2: INSTALLATION & OPERATION ...2**

- Principle of Pump Operation
- Service
- Typical Installation Guide

## **SECTION 3: EXPLODED VIEW.....4**

- Composite Drawings
- Parts List
- Material Codes

## **SECTION 4: WARRANTY & CERTIFICATES ....6**

- Warranty
- EU Declaration of Conformity - Machinery Directive

# Dimensional Drawings

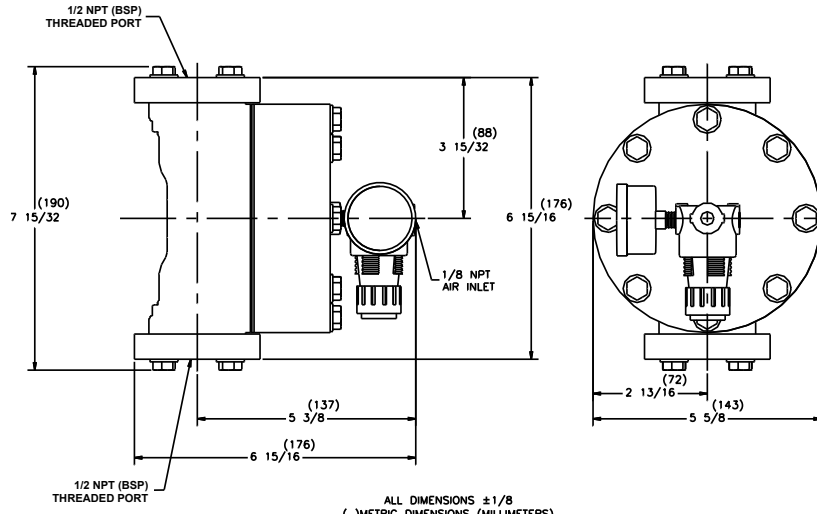

**VDA05**    **Metallic and Non-Metallic**

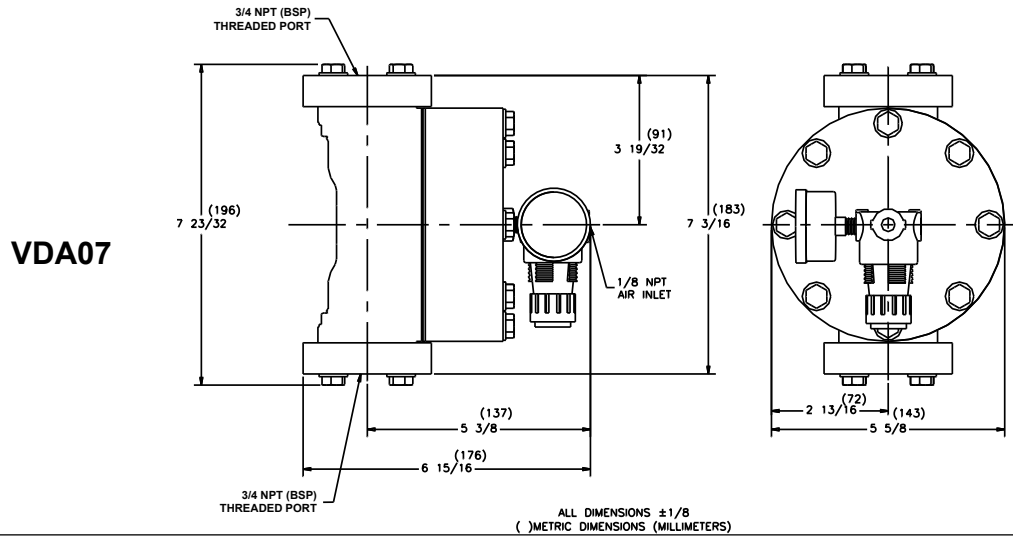

**VDA07**

ANSI STANDARD 125#  
1" FLANGE CONFIGURATION  
TYPICAL EACH END  
ø5/8 (4) HOLES EQUALLY  
SPACED ON A ø3 1/8  
BOLT CIRCLE

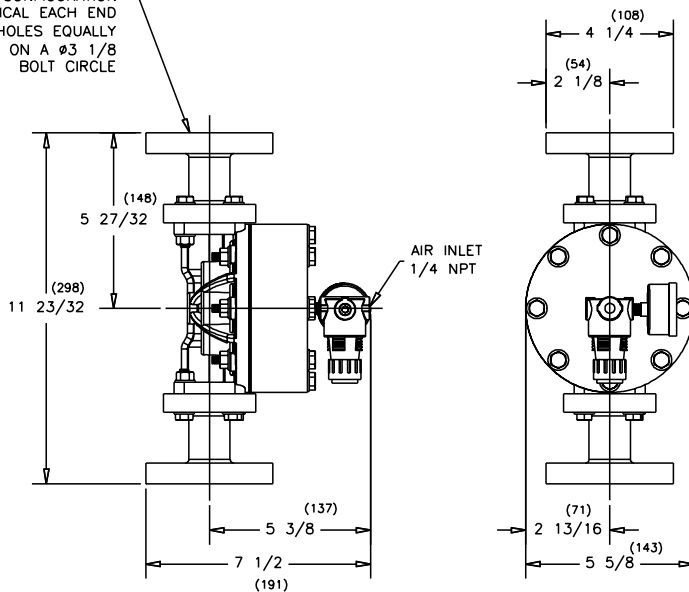

**VDA10**

# Principle of Operation

The Versa-Matic Surge Dampener reduces flow and pressure pulsation which is characteristic of reciprocating pumps.

## PRINCIPLE OF OPERATION

The surge dampener uses a flexible virgin PTFE diaphragm to separate a liquid chamber from a compressed air chamber. After the dampener is manually charged with air, the diaphragm strokes at the same rate as the pump strokes. This movement effectively "dampens" flow and pressure fluctuations.

## TEMPERATURE LIMITATIONS

*Operating temperature limitations are as follows.*

 <b>Material</b>	<b>Minimum Temp.</b>	<b>Maximum Temp.</b>
PVDF	0°F / -18°C	212°F / 100°C
Nylon	32°F / 0°C	180°F / 82°C
Polypropylene	32°F / 0°C	180°F / 82°C
Virgin PTFE	-35°F / -31°C	212°F / 100°C
Nitrile	-10°F / -23°C	190°F / 88°C

## INSTALLATION & START-UP

Locate the unit in the discharge piping near the pump. The dampener will operate in any position. However, when used with liquids that tend to settle out, the unit should be installed at the top side of piping to provide easy discharge of foreign solids by gravity.

Adjust the inlet air pressure to the dampener until the pump runs as smoothly as possible. Watch the liquid discharging, or use a gauge, to detect pressure fluctuations. Then adjust pressure to the unit as needed.

**NOTE:** Self-relieving regulator 020-039-000 will make these adjustments easier.

## SERVICE

When service is required on the dampener, remove the 8 capscrews. The wetted chamber can be removed from the unit and exposes the diaphragm. Remove the diaphragm. When reassembling the wetted chamber onto the air chamber, use a torque wrench set at 70 in/lbs. (7.9 Newton meters)

# Recommended Installation Guide

## Available Accessories:

1. Surge Suppressor
2. Filter/Regulator
3. Air Dryer

**Note:** Surge Suppressor and Piping must be supported after the flexible connection.

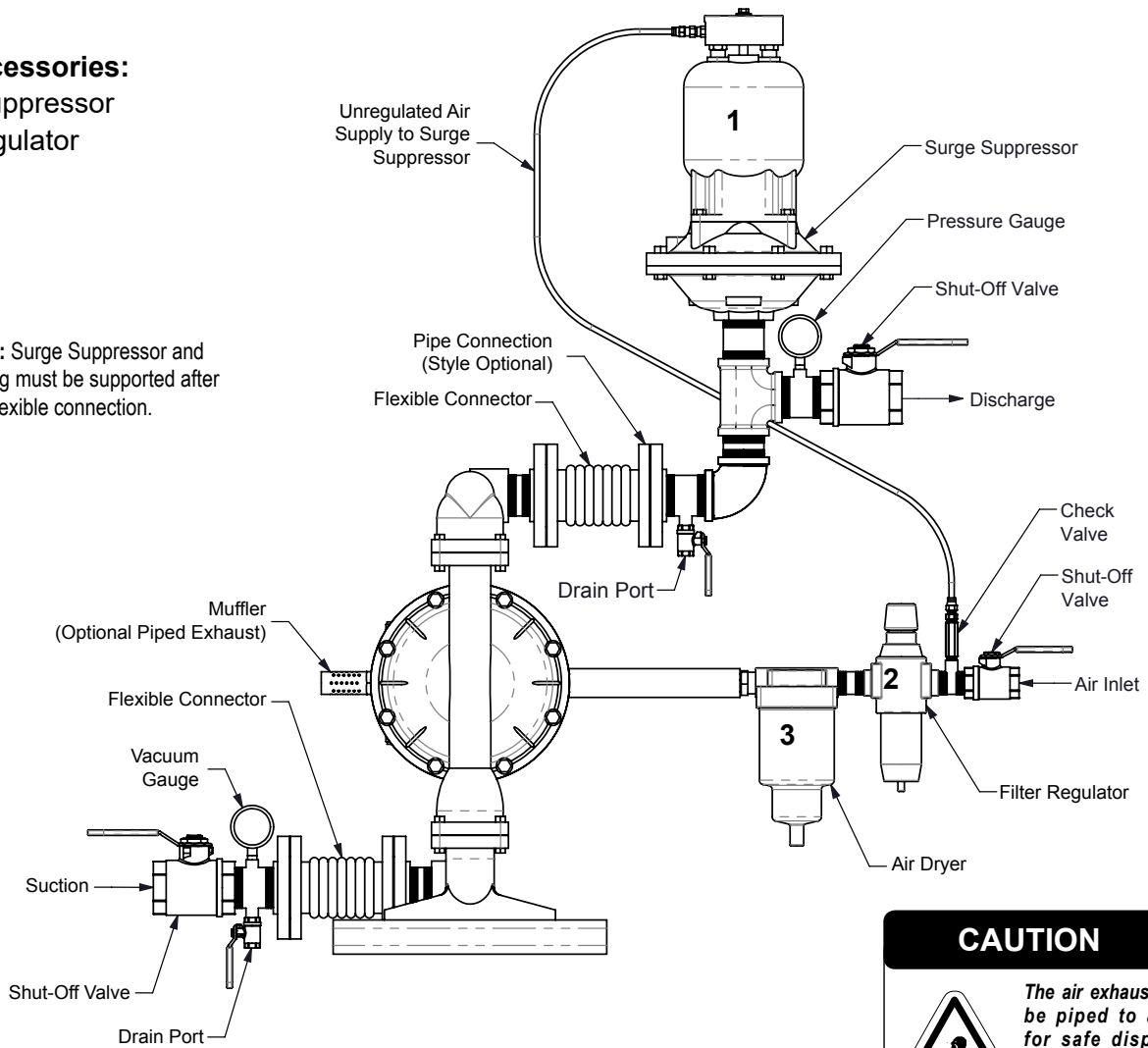

## CAUTION



*The air exhaust should be piped to an area for safe disposition of the product being pumped, in the event of a diaphragm failure.*

## Installation And Start-Up

Locate the pump as close to the product being pumped as possible. Keep the suction line length and number of fittings to a minimum. Do not reduce the suction line diameter.

## Air Supply

Connect the pump air inlet to an air supply with sufficient capacity and pressure to achieve desired performance. A pressure regulating valve should be installed to insure air supply pressure does not exceed recommended limits.

## Air Valve Lubrication

The air distribution system is designed to operate **WITHOUT** lubrication. This is the standard mode of operation. If lubrication is desired, install an air line lubricator set to deliver one drop of SAE 10 non-detergent oil for every 20 SCFM (9.4 liters/sec.) of air the pump consumes. Consult the Performance Curve to determine air consumption.

## Air Line Moisture

Water in the compressed air supply may cause icing or freezing of the exhaust air, causing the pump to cycle erratically or stop operating. Water in the air supply can be reduced by using a point-of-use air dryer.

## Air Inlet And Priming

To start the pump, slightly open the air shut-off valve. After the pump primes, the air valve can be opened to increase air flow as desired. If opening the valve increases cycling rate, but does not increase the rate of flow, cavitation has occurred. The valve should be closed slightly to obtain the most efficient air flow to pump flow ratio.

# Composite Repair Parts Drawing

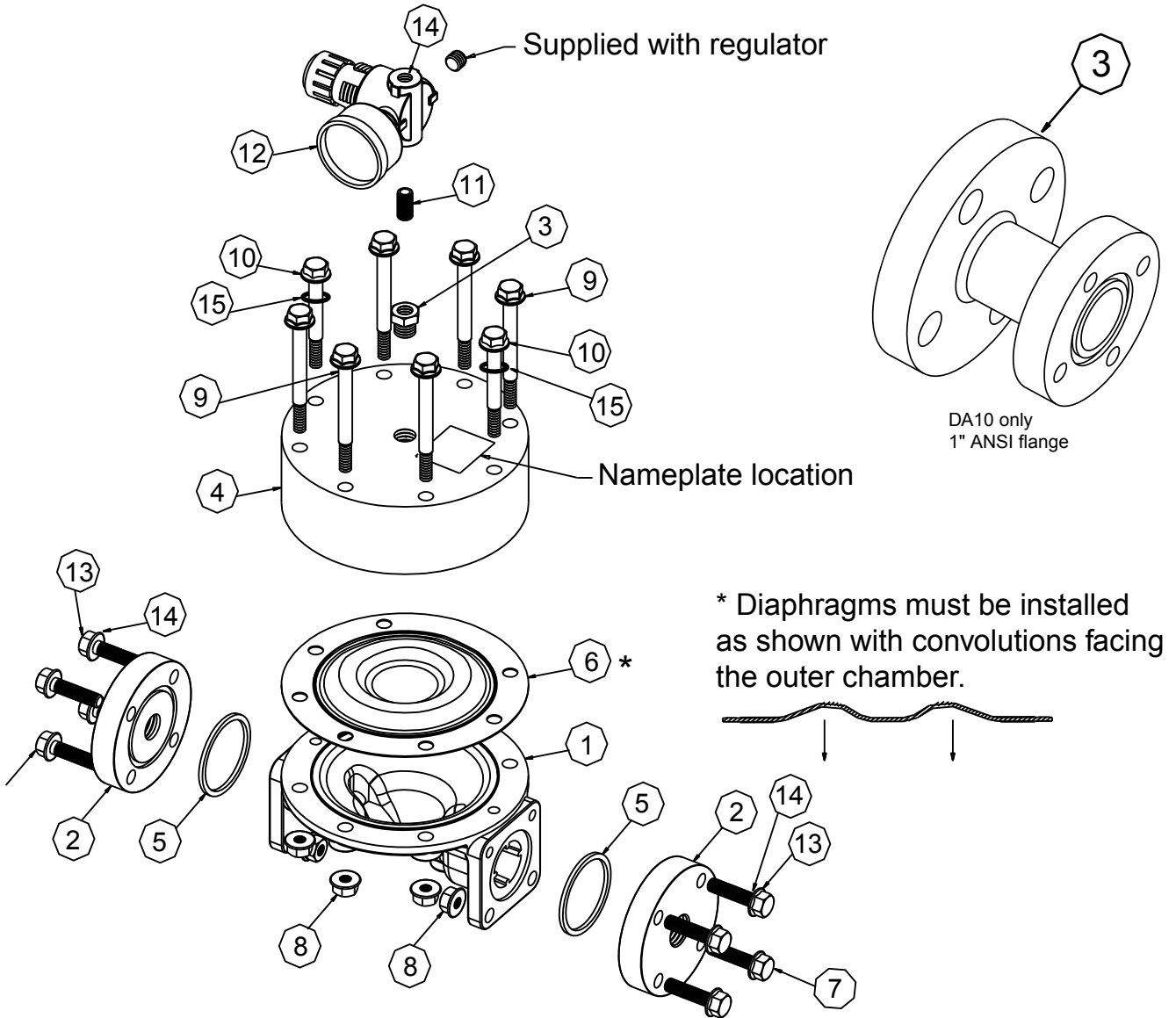

# Composite Repair Parts List

ITEM NO.	PART NUMBER	DESCRIPTION	TOTAL RQD.
1	196-161-552	Chamber, Outer	1
	196-161-520	Chamber, Outer	1
	196-161-542	Chamber, Outer	1
	196-171-110	Chamber, Outer (VDA05 Metallic only)	1
	196-171-157	Chamber, Outer (VDA05 Metallic only)	1
2	334-103-552	Flange, Threaded 1/2" NPT (VDA05)	2
	334-103-542	Flange, Threaded 1/2" NPT (VDA05)	2
	334-103-600	Flange, Threaded 1/2" NPT (VDA05)	2
	334-109-110	Flange, Threaded 1/2" NPT (Metallic VDA05 only)	2
	334-109-150	Flange, Threaded 1/2" NPT (Metallic VDA05 only)	2
	334-104-552	Flange, Threaded 3/4" NPT (VDA07)	2
	334-104-542	Flange, Threaded 3/4" NPT (VDA07)	2
	334-104-600	Flange, Threaded 3/4" NPT (VDA07)	2
	334-107-552	Flange, 1" ANSI (VDA10)	2
3	135-022-115	Bushing, Reducer	2
4	196-166-552	Chamber, Inner	1
5	720-058-600	Seal, Flange	2
	720-063-600	Seal, Flange (Metallic VDA05 only)	2
<b>6</b>	<b>286-097-600</b>	<b>Diaphragm</b>	<b>1</b>
7	171-064-115	Capscrew Hex Flange 5/16 -18 x 1.50	8
	171-064-308	Capscrew Hex Flange 5/16 -18 x 1.50	8
	170-029-330	Capscrew, Hex Flange 5/16 x 1.50 (Metallic VDA05 only)	4
8	544-005-115	Nut 5/16 Hex Flange Nut 5/16-18	10
	544-005-308	Nut 5/16 Hex Flange Nut 5/16-18	10
	545.004-330	Hex Flange Nut (Metallic VDA05 only)	10
9	171-070-115	Capscrew Hex Flange 5/16 -18 x 3.00	6
	171-070-308	Capscrew Hex Flange 5/16 -18 x 3.00	6
	171-070-330	Capscrew, Hex Flange (Metallic VDA05 only)	2
10	171-069-115	Capscrew Hex Flange 5/16 -18 x 2.5	2
	171-069-308	Capscrew Hex Flange 5/16 -18 x 2.5	2
	171-069-330	Capscrew, Hex Flange (Metallic VDA05 only)	2
11	538-002-115	Nipple 1/8 NPT	1
12	020-039-000	Regulator W/Gauge	1
13	170-045-330	Capscrew Hex Flange (VDA05 Metallic Only) 5/16 -18 x 1.25	4
14	900-004-330	LockWasher (VDA05 Metallic Only)	14
15	901-038-115	Flat Washer (Non-Metallic Only)	2

Repair Parts shown in **bold face (darker)** type are more likely to need replacement after extended periods of normal use. They are readily available from most Versa-Matic distributors. The pump owner may prefer to maintain a limited inventory of these parts in his own stock to reduce repair downtime to a minimum.

**IMPORTANT:** When ordering repair parts always furnish pump model number, serial number and type number.

## MATERIAL CODES The Last 3 Digits of Part Number

000...	Assembly, sub-assembly; and some purchased items
110...	CF*M (316) Stainless Steel
115...	302/304 Stainless Steel
157...	380/383 Die Cast Aluminum
308...	Stainless Steel; Black PTFE Coated
330...	Zinc Plated Carbon Steel
360...	Nitrile Rubber. Color coded: RED
520...	Injection Molded PVDF, Natural Color,
542...	Nylon
552...	Polypropylene
600...	Virgin PTFE



# Warranty

## 5 - YEAR Limited Product Warranty

Quality System ISO9001 Certified • Environmental Management Systems ISO14001 Certified

Versamatic warrants to the original end-use purchaser that no product sold by Versamatic that bears a Versamatic brand shall fail under normal use and service due to a defect in material or workmanship within five years from the date of shipment from Versamatic's factory.

The use of non-OEM replacement parts will void (or negate) agency certifications, including CE, ATEX, CSA, 3A and EC1935 compliance (Food Contact Materials). Warren Rupp, Inc. cannot ensure nor warrant non-OEM parts to meet the stringent requirements of the certifying agencies.

~ See complete warranty at [http://vm.salesmrc.com/pdfs/VM\\_Product\\_Warranty.pdf](http://vm.salesmrc.com/pdfs/VM_Product_Warranty.pdf)

### DECLARATION OF CONFORMITY

DECLARATION DE CONFORMITE • DECLARACION DE CONFORMIDAD • ERKLÄRUNG BEZÜGLICH EINHALTUNG DER VORSCHRIFTEN  
DICHIARAZIONE DI CONFORMITÀ • CONFORMITEITSVERKLARING • DEKLARATION OM ÖVERENSSTÄMMELSE  
EF-OVERENSSTÄMMELSESERKLÄRING • VAATIMUSTENMUKAISUUSVAKUUTUS • SAMSVARSERKLÄRING  
DECLARAÇÃO DE CONFORMIDADE

#### MANUFACTURED BY:

FABRIQUE PAR:  
FABRICADA POR:  
HERGESTELLT VON:  
FABBRICATO DA:  
VERVAARDIGD DOOR:  
TILLVERKAD AV:  
FABRIKANT:  
VALMISTAJA:  
PRODUSENT:  
FABRICANTE:

**VERSAMATIC**®  
Warren Rupp, Inc.  
A Unit of IDEX Corporation  
800 North Main Street  
P.O. Box 1568  
Mansfield, OH 44901-1568 USA  
  
Tel: 419-526-7296  
Fax: 419-526-7289



#### PUMP MODEL SERIES: E SERIES, V SERIES, VT SERIES, VSMA3, SPA15, RE SERIES AND U2 SERIES

##### This product complies with the following European Community Directives:

Ce produit est conforme aux directives de la Communauté européenne suivantes:  
Este producto cumple con las siguientes Directrices de la Comunidad Europea:  
Dieses produkt erfüllt die folgenden Vorschriften der Europäischen Gemeinschaft:  
Questo prodotto è conforme alle seguenti direttive CEE:  
Dir produkt voldoet aan de volgende EG-richtlijnen:  
Denna produkt överensstämmer med följande EU direktiv:  
Versamatic, Inc., erklærer herved som fabrikant, at ovennævnte produkt er i overensstemmelse med bestemmelserne i Direktive:  
Tämä tuote täyttää seuraavien EC Direktiivien vaatimukset:  
Dette produkt oppfyller kravene til følgende EC Direktiver:  
Este produto está de acordo com as seguintes Directivas comunitárias:

**2006/42/EC**  
on Machinery, according  
to Annex VIII

##### This product has used the following harmonized standards to verify conformance:

Ce matériel est fabriqué selon les normes harmonisées suivantes, afin d' en garantir la conformité:  
Este producto cumple con las siguientes directrices de la comunidad europea:  
Dieses produkt ist nach folgenden harmonisierten standards gefertigt worden, die übereinstimmung wird bestätigt:  
Questo prodotto ha utilizzato i seguenti standards per verificare la conformità:  
De volgende geharmoniseerde normen werden gehanteerd om de conformiteit van dit produkt te garanderen:  
För denna produkt har följande harmoniserande standarder använts för att bekräfta överensstämmelse:  
Harmoniserede standarder, der er benyttet:  
Tässä tuotteessa on sovellettu seuraavia yhdenmukaistettuja standardeja:  
Dette produkt er produsert i overensstemmelse med følgende harmoniserte standarder:  
Este produto utilizou os seguintes padrões harmonizados para varificar conformidade:

**EN809:2012**

#### AUTHORIZED/ APPROVED BY:

Approuve par:  
Aprobado por:  
Genehmigt von:  
approvato da:  
Goedgekeurd door:  
Underskrift:  
Valtuutettuna:  
Bemyndiget av:  
Autorizado Por:

  
Dave Roseberry  
Director of Engineering  
  
Authorized Representative:  
IDEX Pump Technologies  
R79 Shannon Industrial Estate,  
Shannon, Co. Clare Ireland  
Attn: Barry McMahon

**DATE: February 27, 2017**

FECHA:  
DATUM:  
DATA:  
DATO:  
PÄIVÄYS:



06/14/2017 REV 08

VMQR 044FM



[WWW.VERSAMATIC.COM](http://WWW.VERSAMATIC.COM)

vda050710sdsr-rev0419

Surge Dampeners • 8