

# SERVICE & OPERATING MANUAL

## ORIGINAL INSTRUCTIONS

# VM

## Porta-Matic Model SPA153

Model SPA15-BSP3

### OPERATING INSTRUCTIONS

**THE PUMP:** This pump is a totally enclosed, submersible dewatering unit. It is powered by a 1/3 HP, 12 volt DC 30 AMP motor. Battery clips on the power cord allow easy connection to any 12 volt vehicle battery.

**SWITCHING:** The on-off switch is located on the power cord.

**CONNECTING TO BATTERY:** When connecting the clips to a battery, arcing is eliminated by keeping the on-off switch in the "off" position. Connect the red battery clamp to the positive (+) battery terminal. Connect the black battery clamp to ground: preferably on the vehicle's engine to a solid, metallic, stationary point. The connection should be at least 18 inches (480mm) from the battery.

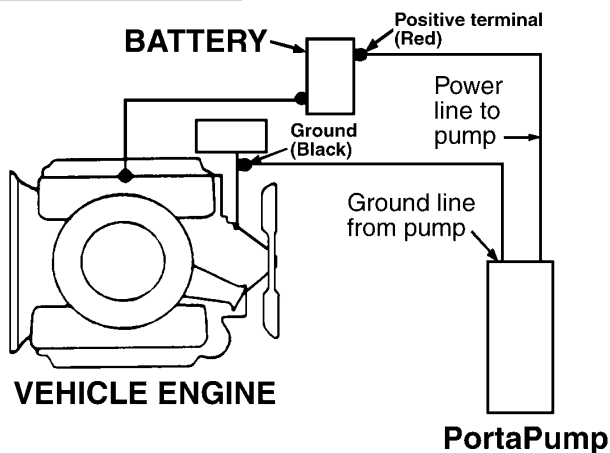

### IMPORTANT SAFETY INFORMATION

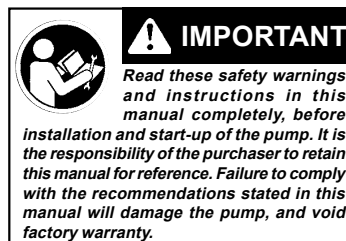

**HOSE:** Since the pump develops relatively low pressure, it is recommended that non-collapsible hose be used for maximum pumping rates.

**HOISTING & LOWERING:** An eye at the top of the unit is provided for attaching a line for hoisting or lowering. **Do not use power cable for handling unit.**

**TO OPERATE:** Lower unit into liquid to be pumped and activate switch. Pump can be run for a few minutes without liquid, however, **do not run completely dry for extended periods.** Damage to shaft seal may result.

**RUNNING TIME:** This unit draws about 30 amperes and can be operated about 1 hour on a fully charged 55 AMP-hour battery and still permit starting of vehicle under normal conditions. Caution should be used when running time exceeds 30 or 40 minutes without engine running to recharge battery, particularly in cold weather when battery efficiency is lowered. Battery size (AMP-hour rating) and the use of other accessories such as lights and radios, etc., must be taken into consideration for practical running periods without engine running.

**OVERLOAD PROTECTION** is provided by means of a 40 amp automatic reset circuit breaker, located under top cover.

1. Make sure the vehicle and the pump are not in contact during connection.
2. Do not use power cable for handling unit.
3. Do not run completely dry for extended periods. Damage to shaft seal may result.

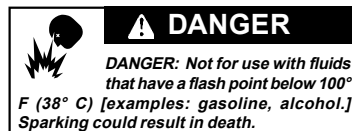

**VERSAMATIC®**  
**ACCESSORIES**

## TROUBLE SHOOTING

**NOTE:** Most common cause of failure to run is due to hardened mud and sand at impeller. Remove strainer to check.

### MOTOR WILL NOT RUN:

1. Poor connection at battery.
2. Impeller locked with foreign material.
3. Insufficient impeller clearance.
4. Damaged power cable or loose connection internally in motor assembly.
5. Bad switch or circuit breaker. Connect power leads direct to motor leads to check.
6. Worn motor brushes or out of position to make contact with armature.

### PERFORMANCE LOW:

1. Strainer screen partially plugged.
2. Impeller rubbing. Check freeness of rotation with screwdriver inserted through hole in base plated into slotted end of shaft.
3. Battery not fully charged.
4. Discharge restriction such as kinked hose or excessive discharge head.

### Motor runs backwards:

1. Check wiring for correct polarity.

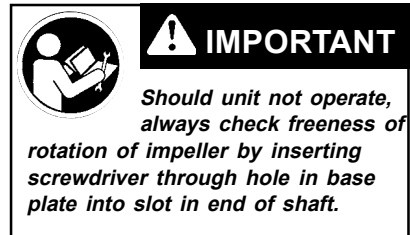

## SERVICE AND REPAIR INSTRUCTION

**DISASSEMBLY:** Impeller and shaft seal can be inspected and serviced from lower end of pump by removal of 4 capscrews securing base plate, strainer screen, and suction cover. Screwdriver slot is provided in end of motor shaft to turn shaft while holding impeller for removal. This permits removal of impeller without disassembly of upper motor housing to hold motor shaft.

To service motor remove 4 hex nuts and bump top cover free from housing tube. Raise sufficiently to disconnect power cable connections. Slide housing tube up from pump casing and motor will be exposed for service or removal.

**IMPORTANT:** Make certain that wire leads are installed per diagram below.

Install top cover as indicated by arrow and instruction on top of cover.

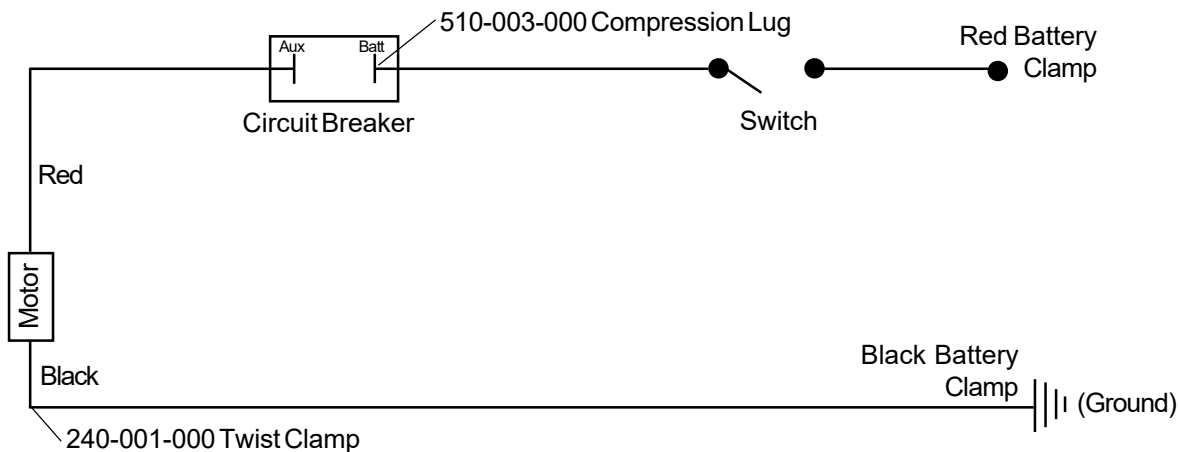

## WARRANTY

This unit is guaranteed for a period of 5 years against defective material and workmanship.

# Composite Repair Parts List

ITEM NO.	PART NUMBER	DESCRIPTION	TOTAL RQD.
1	710-004-330	Screw, Self-Tapping	3
2	258-017-157	Cover, Motor	1
3	545-005-330	Hex Nut	1
4	<b>405-001-000</b>	<b>Handle</b>	1
5	543-001-162	Nut, Gland	2
6	770-007-162	Spacer, Gland	2
7	<b>675-016-360</b>	<b>Ring, Sealing</b>	2
8	545-004-330	Hex Nut	4
9	900-004-330	Lock Washer	4
10	807-011-330	Stud	4
11	<b>270-001-000</b>	<b>Circuit Breaker</b>	1
12	170-028-330	Capscrew, Hex Head	4
13	900-001-330	Lock Washer	8
14	<b>360-001-440</b>	<b>Gasket, Casing</b>	5
15	170-003-115	Capscrew, Hex Head	4
16	<b>444-001-010</b>	<b>Impeller</b>	1
17	<b>740-001-115</b>	<b>Shim</b>	As. Req.*
18	258-001-157	Cover, Suction	1
19	612-001-156	Plate, Strainer	1
20	700-001-330	Screen, Strainer	1
21	181-001-155	Casing, Volute, 1½ NPT	1
	181-001-155E	Casing, Volute, 1½ BSPT (tapered)	1
22	<b>560-022-360</b>	<b>O-Ring</b>	2
23	<b>720-005-000</b>	<b>Seal</b>	1
24	860-011-150	Tube, Casing	1
25	525-005-000	Motor	1
26	200-003-000	Clamp, Cable	1
27	706-007-330	Screw, Machine	1
28	150-036-000	Power Cable Assembly Complete	1
29	900-002-330	Washer, Lock	1
30	510-003-000	Lug, Compression	1
31	240-001-000	Nut, Insulated Wire	1

Repair Parts shown in **bold face (darker)** type are more likely to need replacement after extended periods of normal use. They are readily available from most Warren Rupp distributors. The pump owner may prefer to maintain a limited inventory of these parts in his own stock to reduce repair downtime to a minimum.

**IMPORTANT:** When ordering repair parts always furnish pump model number, serial number and type number.

## MATERIAL CODES

### The Last 3 Digits of Part Number

000...	Assembly, sub-assembly; and some purchased items
010...	Cast Iron
012...	Powered Metal
015...	Ductile Iron
020...	Ferritic Malleable Iron
025...	Music Wire
080...	Carbon Steel AISI B-112
100...	Alloy 20
110...	Alloy Type 316 Stainless Steel
111...	Alloy Type 316 Stainless Steel (Electro Polished)
112...	Alloy "C"
113...	Alloy Type 316 Stainless Steel (Hand Polished)
114...	303 Stainless Steel
115...	302/304 Stainless Steel
117...	440-C Stainless Steel (Martensitic)
120...	416 Stainless Steel (Wrought Martensitic)
123...	410 Stainless Steel (Wrought Martensitic)
148...	Hardcoat Anodized Aluminum
149...	2024-T4 Aluminum
150...	6061-T6 Aluminum
151...	6063-T6 Aluminum
152...	2024-T4 Aluminum (2023-T351)
154...	Almag 35 Aluminum
155 or 156...	356-T6 Aluminum
157...	Die Cast Aluminum Alloy #380
158...	Aluminum Alloy SR-319
159...	Anodized Aluminum
162...	Brass, Yellow, Screw Machine Stock
165...	Cast Bronze, 85-5-5-5
166...	Bronze SAE 660
170...	Bronze, Bearing Type, Oil Impregnated
180...	Copper Alloy
310...	Kynar Coated
330...	Zinc Plated Steel
331...	Chrome Plated Steel
332...	Electroless Nickel Plated
335...	Galvanized Steel
336...	Zinc Plated Yellow Brass
337...	Silver Plated Steel
340...	Nickel Plated
342...	Filled Nylon
354...	Injection Molded #203-40 Santoprene
	- Duro 40D ± 5; Color: RED
355...	Thermoplastic Elastomer
356...	Hytel
357...	Rupplon (Urethane Rubber) Color coded: PURPLE
358...	Rupplon (Urethane Rubber)
	Color coded: PURPLE
	(Some Applications, Compression Mold)
359...	Urethane Rubber
360...	Buna-N Rubber Color coded: RED
361...	Buna-N
363...	Viton (Fluorel) Color coded: YELLOW
364...	E.P.D.M. Rubber Color coded: BLUE
365...	Neoprene Rubber Color coded: GREEN
366...	Nitrile, USDA Approved
368...	EPDM, USDA Approved

List continued next page

### For Models SPA153F, 12 DC3 and SPa15BSP3F, 12DC3: (Not Shown)

10	807-011-330	Stud	2
	807-012-330	Stud (replaces 2 807-011-330)	2
	325-001-330	Foot, Mounting	2
	547-001-330	Stop Nut 5/16-18Vac	2
	904-001-330	Washer	2

### Service Items: (Not Shown)

526-001-000	Brush	2 per motor
475-220-000	Design Level 2 to Design Level 3 Conversion Kit	

\* Typically 7

\*\* Items 30 & 45 available as a kit #475-132-000

# Composite Repair Parts Drawing

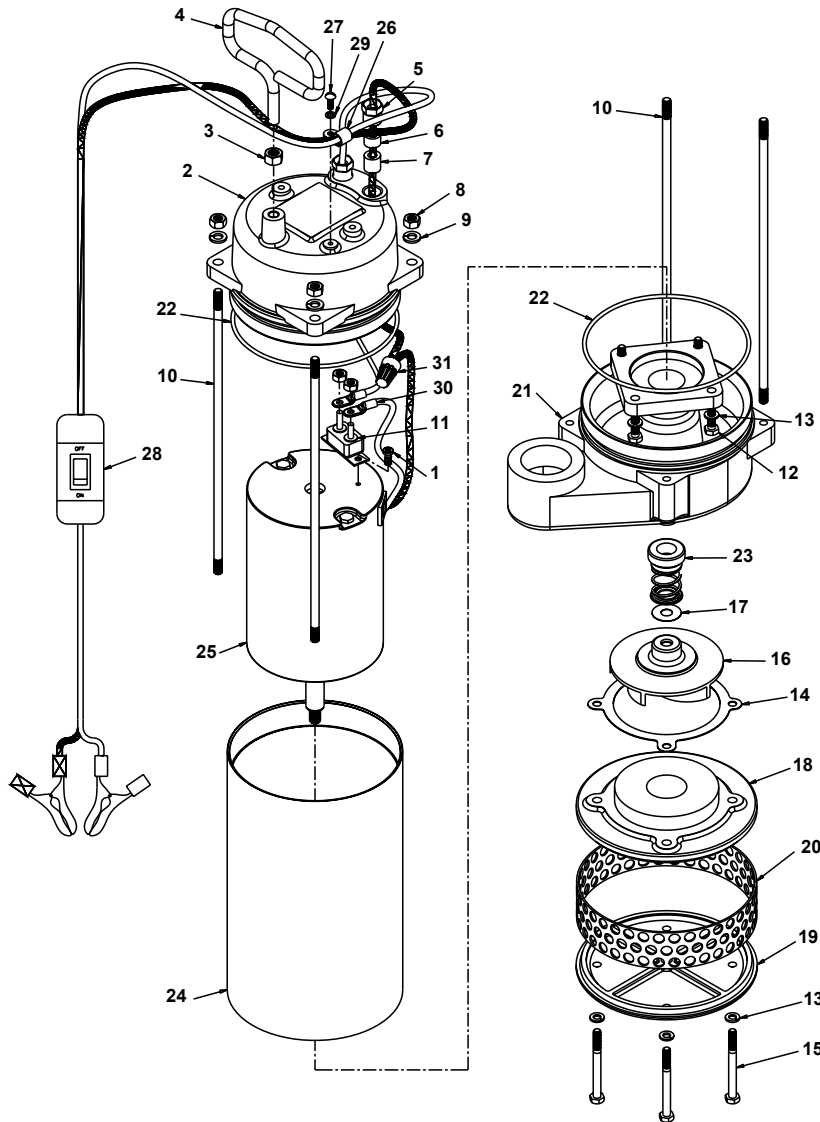

Repair Parts shown in **bold face (darker)** type are more likely to need replacement after extended periods of normal use. They are readily available from most Warren Rupp distributors. The pump owner may prefer to maintain a limited inventory of these parts in his own stock to reduce repair downtime to a minimum.

**IMPORTANT:** When ordering repair parts always furnish pump model number, serial number and type number.

## MATERIAL CODES The Last 3 Digits of Part Number

*Continued from previous page*

- 370...Butyl Rubber Color coded: BROWN
- 371...Phlithane (Tuftane)
- 375...Fluorinated Nitrile
- 378...High density Polypropylene
- 405...Cellulose Fibre
- 408...Cork and Neoprene
- 425...Compressed Fibre
- 426...Blue Gard
- 440...Vegetable Fibre
- 465...Fibre
- 500...Delrin 500
- 501...Delrin 570
- 505...Acrylic Resin Plastic
- 520...Injection Molded PVDF Natural Color
- 540...Nylon
- 541...Nylon
- 542...Nylon
- 544...Nylon Injection Molded
- 550...Polyethylene
- 551...Polypropylene
- 552...Unfilled Polypropylene
- 553...Unfilled Polypropylene
- 555...Polyvinyl Chloride
- 570...Rulon II
- 580...Ryton
- 590...Valox
- 591...Nylatron G-S
- 592...Nylatron NSB
- 600...Virgin PTFE Tetrafluoroethylene (TFE)
- 601...Virgin PTFE (Bronze and moly filled)
- 602...Filled Virgin PTFE
- 603...Blue Gylon
- 604...Virgin PTFE
- 606...Virgin PTFE
- 610...Virgin PTFE Encapsulated Silicon
- 611...Virgin PTFE Encapsulated Viton

Delrin, Viton and Hytre are registered tradenames of E. I. DuPont.

Gylon is a registered tradename of Garlock, Inc.

Nylatron is a registered tradename of Polymer Corp.

Rulon II is a registered tradename of Dixon Industries Corporation.

Hastelloy-C is a registered tradename of Cabot Corp.

Ryton is a registered tradename of Phillips Chemical Company.

Valox is a registered tradename of General Electric Company.